

X-Rotor USER MANUAL
Multi-Rotor
 Brushless Electronic Speed Controller
 XRotor Pro 25A Circular

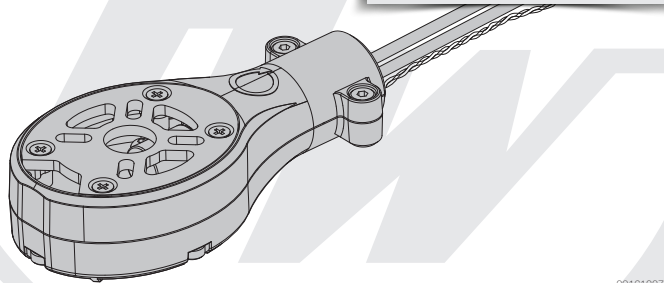

20161227



Thank you for purchasing this HOBBYWING product! Brushless power systems can be very dangerous. Any improper use may cause personal injury and damage to the product and related devices. We strongly recommend reading through this user manual before use. Because we have no control over the use, installation, or maintenance of this product, no liability may be assumed for any damage or losses resulting from the use of the product. We do not assume responsibility for any losses caused by unauthorized modifications to our product. We, HOBBYWING, are only responsible for our product cost and nothing else as result of using our product.

01 Features

- The ESCs can perfectly match the carbon fiber arms with the outer diameter of 16mm.
- The integrated design of ESC and motor mount not only simplifies wiring but prevents dirt, raindrops and spray from getting inside.
- Special core program for multi-rotor controllers greatly improves throttle response.
- DEO (Driving Efficiency Optimization) technology significantly improves throttle linearity and driving efficiency.
- Highly intelligent and adaptive default settings like auto-adjusting timing meet almost all applications.
- The twisted-pair design of the throttle signal cable effectively reduces the crosstalk produced in signal transmission and makes flight more stable.
- Compatible with various flight-controllers and supports a throttle signal frequency of up to 621Hz.
- The high-light LED position on the XRotor Pro Circular 25A ESC saves the trouble of mounting any extra color light on multi-rotors.

02 Specifications

Model	Con. C	Peak C (10s)	BEC	Drive Mode	LiPo	Programmable Item	Weight	Size
XRotor Pro 25A Circular	25A	40A	No	Square Wave Drive	3-6S	Timing (Intermediate/High)	50.5g (Motor Mount Included)	89.3x44.5x20.9mm

03 Different Versions of XRotor Pro Circular 25A ESCs

Version 1: with Red motor mount, Red LED, and the Motor Rotation has been permanently set to "CW".

Version 2: with Red motor mount, Red LED, and the Motor Rotation has been permanently set to "CCW".

Version 3: with Black motor mount, Green LED, and the Motor Rotation has been permanently set to "CW".

Version 4: with Black motor mount, Green LED, and the Motor Rotation has been permanently set to "CCW".

04 User Guide

Throttle Calibration & ESC Programming

- Users need to calibrate the throttle range when they start to use a new XRotor Pro Circular ESC or another transmitter.

1 Motor Wiring

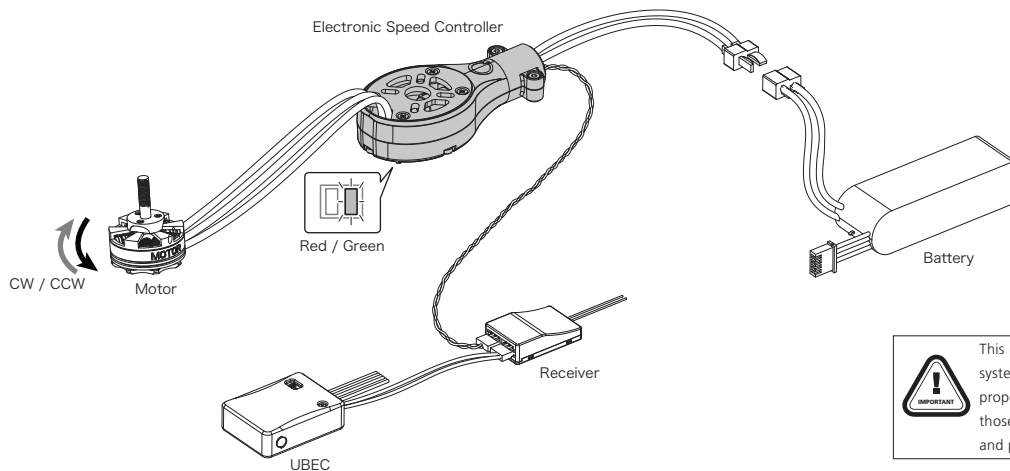

2 Throttle Range Calibration

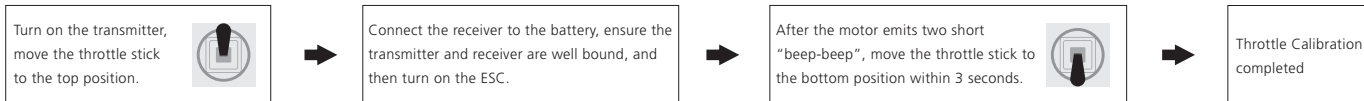

3 ESC Programming

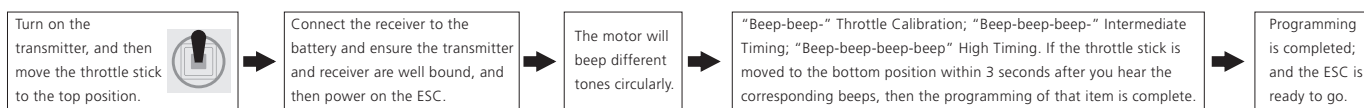

Generally speaking, intermediate timing is applicable for most motors and it brings higher efficiency but less heat to the power system. High timing can increase the RPM of the motor, but it also increase the motor temperature. Please perform a test flight on the ground and ensure everything is functioning properly first, then fly you aircraft into the sky.

04 Normal Start-up Process and Protections

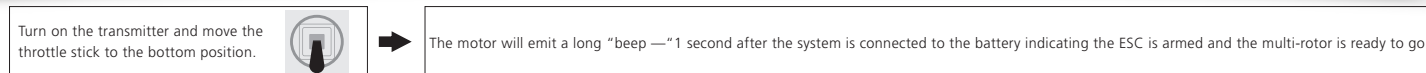

Start-up Protection: The ESC will shut down the motor if it fails to start the motor normally within 2 seconds by increasing the throttle value. In this case, you need to move the transmitter throttle stick back to the bottom position and restart the motor. (Possible causes of this problem: poor connection/ disconnection between the ESC and motor wires, propellers are blocked, etc.)

Over-load Protection: The ESC will cut off the power/output when the load suddenly increases to a very high value. Normal operation will not resume until the throttle stick is moved back to the neutral position. The ESC will automatically attempt to restart when the motor and the ESC are out of sync.

Throttle Signal Loss Protection: When the ESC detects loss of signal for over 0.25 second, it will cut off the output immediately to avoid an even greater loss which may be caused by the continuous high-speed rotation of propellers or rotor blades. The ESC will resume the corresponding output after normal signals are received.

05 Trouble shooting

Trouble	Warning Tone	Possible Cause	Solution
The ESC was unable to start the motor.	"Beep beep beep..." (The motor beeps rapidly)	The throttle stick is not at the bottom position.	Move the throttle stick to the bottom position or recalibrate the throttle range.
The ESC was unable to start the motor.	"Beep, beep, beep....." (Time interval is 1 second)	No output signal from the throttle channel on the receiver.	Check if the transmitter and receiver are well bound; Check if the throttle wire has been properly plugged into the throttle channel on the receiver.
The ESC was unable to start the motor.	"BB, BBB, BBBB" (These tones are played circularly)	The "Normal / Reverse" direction of the throttle channel on transmitter is incorrect.	Refer to the transmitter instructions and correctly set the "Normal/ Reverse" direction of the throttle channel.