

01 Disclaimer

EZRUN

USER MANUAL

Brushless Electronic Speed Controller
EZRUN MAX6 G2

20230830

HW-SMA433DUL00-A0



Thank you for purchasing this HOBBYWING product! Please read the following statement carefully before use and, once used, it is considered to be an acceptance of all the contents. Please strictly observe and adhere to the manual installation with this product. Unauthorized modification may result in personal injury and product damage. We reserve the rights to update the design and performance of the Product without notice. Different languages are available. Chinese language will be available to the mainland of China while English language will be available to the rest of the world.



02 Warnings

- Before using this product, read the instruction manual carefully. Ensure that the equipment is used appropriately to avoid damaging the ESC. The wrong usage will overheat and damage the electronics.
- It is important to ensure that all wires soldered are properly secured to avoid short circuits from happening. A good soldering station is recommended to do such a job to avoid overheating the circuit board as well as to ensure connections are properly soldered.
- Even though the product has relevant protective measures, always use it in a safe manner in accordance with the operating environment noted in the manual (e.g. voltage, current, temperature and etc).
- Always remember to disconnect the battery each time after using it. Failure to do so will cause the battery to be completely discharged, resulting in an unpredictable danger.

03 Features

- The esc has an innovative waterproof sensor interface, enhancing the overall waterproof and dustproof performance. It is easy to deal with the harsh conditions containing sediment, ice and snow, water accumulation.
- Built-in ultra-powerful switch mode BEC with a continuous current of 8A, an instant 25A, and support for 6V/7.4V/8.4V switching, supporting a wide range of powerful and high-voltage servos.
- Supports turbo timing setting, the timing response is remarkable when used with the matching motor(such as EZRUN 4990SD/5690SD G2).
- Multiple protection functions: battery low voltage protection, ESC and motor overheat protection, signal loss protection, current protection.
- The built-in (integrated in the switch) Bluetooth function allows for setting and upgrading the esc by directly connecting to the mobile app, without any additional devices, making it simpler and more convenient.
- Data logging function to view various running data on the HW LINK app.
- Supports the firmware upgrade of the ESC, you can enjoy the latest functions.

04 Specifications

MODEL	EZRUN MAX6 G2
Cont. / Peak Current	200A / 1200A
Motor Type	Sensored / Sensorless Brushless Motor
Applications	1/6&1/7 On-road, Truck, Monster Truck
Motor Limit (Note*)	With 6S Lipo: KV < 2400 With 8S Lipo: KV < 1700 4990/5690 size motor
Lipo Cells	3-8S Lipo
BEC Output	6V/7.4V/8.4V adjustable, continuous current 8A (Switch-mode)
Cooling Fan	A stable 6V or 7.4V or 8.4V from the built-in BEC
Size / Weight	70(L) x 56(W) x 45.5(H)mm / 245g (Included input wires)
Programming Method	iOS or Android smart phone (installed with the HW LINK app)

Note *: The range of KV value here is the recommended value under the standard application (combined with the rpm supported by the motor and the actual load of the whole vehicle), and does not represent the maximum rpm supported by esc.

05 Connections

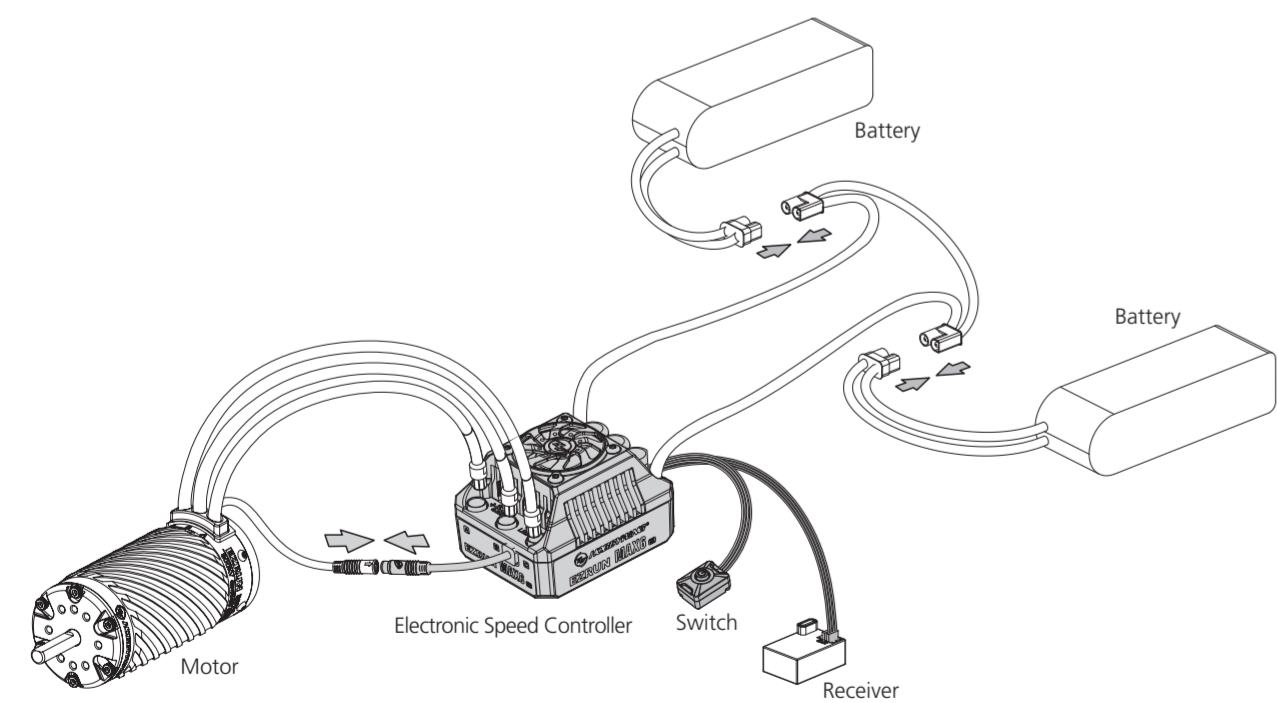

Refer to the wiring instructions and wiring diagram:

1. Motor connection:

There is a difference between connecting a sensored brushless motor and a sensorless brushless motor:

A. When connecting to a sensored brushless motor:
There are strict wire sequencing requirements for connecting the ESC to the motor, **the three A/B/C ESC wires must connect to the three A/B/C motor wires correspondingly, otherwise, it may damage the ESC.** Next, connect the sensor cable of the esc and motor according to the arrow mark on the sensor connector. If you don't plug the sensor cable in, your ESC will still work in sensorless mode even if you're using a sensored motor.

Note: If the motor direction is reversed, change the parameter on item 4 "Motor rotation direction" to achieve the correct setting.

B. When connecting to a sensorless brushless motor:

There are no wire sequencing requirements needed when using a sensorless brushless motor, you can swap two wires if the motor runs in opposite direction.

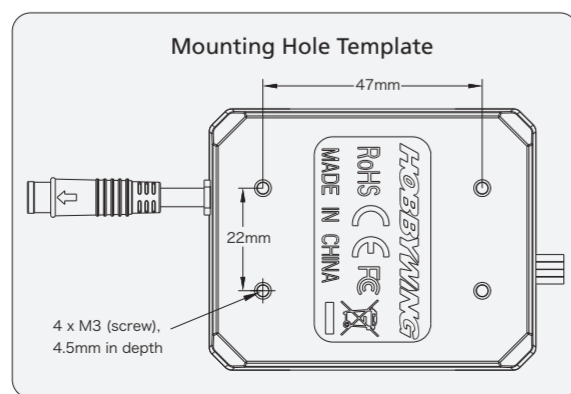

2. Receiver connection:

Connect the ESC throttle cable to the throttle channel on the receiver. Since the throttle cable of esc will have BEC voltage output to the receiver and servo, please do not supply additional power to the receiver, otherwise the esc may be damaged. If additional power is required, disconnect the red wire on the throttle plug from the ESC.

3. Battery connection:

Make sure that the (+) pole of the ESC is connected to the (+) pole of the battery and (-) to the (-). If the connection is reversed, the ESC will be damaged and will not be covered by the warranty.

06 ESC Setup

1 Set the Throttle Range - ESC Calibration Process

When first use the ESC or the transmitter changes "TRIM" tune, D/R, EPA and other parameters, the throttle range is need to reset. We strongly recommend to open the fail safe function of the transmitter, set the no signal protection of throttle channel ("FS") to close the output or set the protection value to the throttle neutral position. Thus the motor can stop running if the receiver cannot receive the signal of the transmitter. The calibrating steps of throttle is as follows:

2 Power on/off and beep instructions

Switch instructions: short press power button to power-on, long press on power button to shut down.

Power-on beep description: Under normal circumstances, the ESC will emit a few "beep" to indicate the number of lithium cells. A short "beep-" means the #1, and a long "beep—" means the #5. For example: "beep—, beep—" means 6 cells, "beep—, beep-beep-beep—" means 8 cells.

Note: Motor beeping at the same time, the ESC light flashes synchronously. For example: when the motor makes a long beep, the esc flashes for a long time, and when the motor makes a short beep, the esc flashes for a short time.

3 Instruction for programmable items

The column of white words on black background in the following table are the default values of programmable items.

Item	Option 1	Option 2	Option 3	Option 4	Option 5	Option 6	Option 7	Option 8	Option 9
1 Running Mode	Forward with brake	Forward / Reverse with Brake	Forward with reverse						
2 Lipo Cells	Auto	2S	3S	4S	5S	6S	7S	8S	
3 Cutoff Voltage	Disabled	Auto (low)	Auto (medium)	Auto (high)					
4 Motor Rotation	CCW	CW							
5 BEC Voltage	6.0V	7.4V	8.4V						
6 Max.Brake Force	12.50%	25%	37.50%	50%	62.50%	75%	87.50%	100%	Disabled
7 Max.Reverse Force	25%	50%	75%	100%					
8 Punch	Level 1	Level 2	Level 3	Level 4	Level 5	Level 6	Level 7	Level 8	Level 9
9 Drag Brake Force					0-100% (Adjust Step 1%)	Default 0%			
10 Initial Throttle Force	0.5%	1%	2%	3%	4%	5%	6%	7%	8%
11 Turbo Timing	0°	4°	8°	12°	16°	20°	24°		
12 Turbo Delay	Instant	0.05s	0.1s	0.15s	0.2s	0.3s	0.5s	0.7s	1.0s

1. Running Mode:

Option 1: Forward with brake

The vehicle can only move forward and has brake function. This is also commonly acceptable at races.

Option 2: Forward/Reverse and Brake

This option is known to be the "training" mode with "Forward/Reverse with Brake" function. The vehicle only brakes on the first time you push the throttle trigger to the reverse/brake position. If the motor stops when the throttle trigger return to the neutral position and then re-push the trigger to reverse position, the vehicle will reverse, if the motor does not completely stop, then your vehicle won't reverse but still brake, you need to return the throttle trigger to the neutral position and push it to reverse again. This method is for preventing vehicle from being accidentally reversed.

Option 3: Forward and Reverse

When the throttle trigger is pushed from neutral to reverse position, the motor reverses. This mode is generally used in special vehicles.

2. Lipo Cells:

Set the correct value according to the actual number of Lipo batteries used. The default is automatically calculated. Please note the "Auto" option will not recognize 5S and 7S, this is to avoid mis-calculation during actual use, for example, 6S Lipo without power may be incorrectly calculated as fully charged 5S Lipo. Therefore, this parameter value needs to be manually set when using 5S or 7S Lipo.

Note: The "2S" option here is only reserved in the parameter table, due to the circuit characteristics and the suitable application of this esc, 2S Lipo is not supported.

3. Low Voltage Cut-Off:

This function is mainly to prevent excessive discharge of lithium batteries causing damage. The ESC monitors the battery voltage at all times, and once the voltage falls below the set threshold, the power output is reduced and the power output is completely cut off after a few seconds. When the voltage protection is entered, the red LED flashes in the "-", "-", ". The three levels of low, medium and high here correspond to 2.8V/Cell, 3.1V/Cell and 3.4V/Cell respectively. For NiMH batteries, it is recommended to set this parameter to "Disabled".

4. Motor Rotation:

Setting the rotation of the motor. Due to some differences with the drivetrains on different car kits, it is possible to that the car will go in the opposite direction upon full throttle. In the event that this happens, you can set the "motor rotation direction" to the opposite direction; "CW" or "CCW".

5. BEC Voltage:

BEC voltage support 6V/7.4V/8.4V. Generally, 6.0V is suitable for standard servos, while 7.4V/8.4V is suitable for high-voltage servos. Please set according to the servo specifications.

WARNING! Do not set the BEC voltage above the maximum operating voltage of the servo, as this may damage the servo or even the ESC.

6. Max. Brake Force:

This ESC provides proportional braking function; the braking effect is decided by the position of the throttle trigger. It sets the percentage of available braking power when full brake is applied. Large amount will shorten the braking time but it may damage your pinion and spur gear.

7. Max. Reverse Force:

Refers to the reversing speed. Selecting different parameter values can produce different reversing speed. It is recommended to use a smaller reversing speed to avoid errors caused by reversing too quickly.

8. Punch:

Punch can be used to control overall motor response, in relation to the throttle input. The higher the set value, the faster the acceleration. Lower punch settings are advised for softer starts, lower traction, or to help with motor hesitations or stuttering when throttle is applied rapidly.

9. Drag Brake Force:

Refers to the brake force generated by the motor when the throttle trigger returns to neutral position. Typically drag brake will be 0. Drag brake can add some heat so use only as needed.

10. Initial Throttle Force:

It also called as minimum throttle force. Adjusting this setting to the available traction can help with acceleration. Set a lower value for low traction surfaces, and higher values for higher traction surfaces.

11. Turbo Timing:

It can be used to provide more top speed (at full throttle). The higher the value the higher the motor RPM will reach. PLEASE NOTE: Using the Turbo Timing will increase the running current, and temperatures of the motor and ESC. Use this with caution.

12. Turbo Delay:

When "TURBO DELAY" is set to "INSTANT", the Turbo Timing will be activated right after the throttle trigger is moved to the full throttle position. If the delay is set the Turbo Timing will be delayed for the set amount, the throttle will need to be held at full throttle for the set delay before it initiates.

4 Programming method

Program your ESC with a smart phone (installed with the HW LINK V2 app)

The esc already has a built-in Bluetooth module (integrated into the switch), which supports direct use of the mobile app for parameter setting, firmware updating and data reading without the need for additional devices. The specific methods are as follows:

- Download and install the Hobbywing's official app "HW LINK V2" on your smart phone. For smart phones with the iOS operating system, please search "Hobbywing" in the App Store; for smart phones with the Android operating system, search "Hobbywing" in the Google Play or download it from our website. (https://www.hobbywing.com)
- Connect a battery to the ESC and turn it on, then open the Hobbywing official app "HW LINK V2" on your smart phone. It will ask if you want to connect "Bluetooth" or "WiFi" the first time when you open the app; at this point, please select "Bluetooth". You need to change the connection to "Bluetooth" after using the "WiFi" connection, you can click "Settings" (on the home page) and then "Select the connecting mode" to change the connection.
- A list of Bluetooth devices will pop out when you click the ESC icon on the upper right corner, then select the ESC you want to program to establish the Bluetooth connection between the ESC and smart phone. (Note: the default name & password of the Bluetooth device are HW_BLE**** & 888888.)

ESC Setup: Click **【Parameters】** on the home page to adjust the ESC parameters, click the ESC icon on the upper right corner to disconnect the Bluetooth connection between the ESC and smart phone after completing and saving the settings.

Firmware Updating: Click **【Firmware Update】** and then select the **【Available Version】** to select the firmware version you need, and then click "Update" to upgrade your ESC.

Data Logging: Click on the **【Data Log】** on the homepage of the APP, select **【Data Record(Car)】** to view the five extreme value data stored in the esc; Select **【Real-time Data】** to view the real-time running data; Click on the **【History】** button in the upper right corner of the **【Real-time Data】** page to view the whole historical running data (curve chart).

5 Factory reset

Restore the default values (only the ESC parameters) with a smart phone (installed with the HW LINK app):

After entering the app and establishing the Bluetooth connection between the ESC and smart phone, click "Factory Reset" in "Parameters" to factory reset your ESC. After that, please re-calibrate the throttle range.

Use the switch button to restore the factory Bluetooth name and password:

Connect the esc to the battery and the esc is in the off state. Press and hold the switch button for about 8 seconds. The RED LED in the switch will flash first, and then both the RED and GREEN LEDs will light up, indicating that the factory Bluetooth name and password have been successfully restored, release the button, and the esc will automatically restart. The default factory name for Bluetooth is: HW_BLE * * * * and the default password is 888888

07 Explanation for LED status

1. The run status indication:

- 1) The throttle trigger is in the neutral point and the LED lights are off.
- 2) When advancing, the red light is constantly on, and when the throttle is at full throttle, the green light is on.
- 3) When reversing, the red light is constantly on; if the reversing force is set to 100%, the green light is also lit when the throttle is at the maximum of the reverse.

2. What the LED means when the relevant protection function is triggered:

- 1) The red light flashes (single flash, "☆, ☆, ☆"): enters the low voltage protection state.
- 2) The green light flashes (single flash, "☆, ☆, ☆"): enters the esc overheat protection state.
- 3) The green light flashes (double flash, "☆☆, ☆☆, ☆☆"): enters the motor overheat protection state.

Note: Motor overheat protection is effective only when Hobbywing supporting motor (such as EZRUN 5690SD/4990SD G2) is used. When non Hobbywing supporting motor is used, there is no motor overheat protection function.

- 4) The green light flashes (three flashes, "☆☆☆, ☆☆☆, ☆☆☆"): enters the current protection state.
- 5) The green light flashes (five flashes, "☆☆☆☆☆, ☆☆☆☆☆, ☆☆☆☆☆"): enters the capacitor overheat protection state.

08 Trouble Shooting

Troubles	Possible Causes	Solution
The light does not turn on after power-up, the motor does not start, and the fan does not work.	1. The battery voltage is not output to the ESC; 2. The switch is damaged.	1. Check the battery and whether the connection between battery and esc is good and whether the plug is soldered well; 2. Replace the switch.
The motor does not start after power-up, with a "beep-beep-, beep-beep-" warning tone accompanied by a flashing red light (approximately 0.5 seconds for each set of two-tone intervals).	The battery pack voltage is not within the range of support.	Check the battery voltage or change the battery for testing.
After power on, the red light flashes quickly.	1. The throttle signal is not detected by the ESC; 2. The neutral point of the ESC is not calibrated correctly.	1. Check if the throttle wire is plugged into the correct channel. Check if your transmitter is turned on. Check if the receiver ok. 2. Recalibrate the throttle travel.
The car is going in the reversed direction when the forward throttle is applied.	The transmission on the vehicle is different	Set the parameter item "Motor Rotation" to the opposite direction.
The motor suddenly stopped or significantly reduced the output in running.	1. Possible interference; 2. The ESC enters into low-voltage protection state; 3. The ESC enters into overheat protection state.	1. Check the cause of the interference in the receiver and check the battery level of the transmitter; 2. Replace the battery if red light keeps flashing; 3. The green light continues to flash for temperature protection, please continue to use after the ESC or motor temperature is reduced (it is recommended to reduce the load on the vehicle).
The motor stuttered and unable to start.	1. The motor is connected incorrectly; 2. ESC fault (partial power MOSFET burned out).	1. Check the plugs and the solder points and whether the sequence of A, B and C wires is correct; 2. Contact the dealer to handle the repair.
Going forward normally, but not reverse.	1. The neutral point of the remote control throttle channel deviates from the brake area; 2. The parameter item "Running Mode" is set incorrectly; 3. The ESC is damaged.	1. Recalibrate the esc, when the throttle trigger is at the neutral point, the esc lights are off; 2. Set the "Running Mode" to "Forward/Reverse with Brake"; 3. Contact the distributor to handle the repair.
The throttle travel setting could not be completed.	The ESC did not receive the correct throttle signal.	1. Check whether the throttle cable is correctly connected to the receiver. 2. If the servo works normally, you can connect the throttle cable of esc to the steering column to have a test, or change the transmitter/receiver system for test directly.

09 FCC Information

This equipment complies with FCC radiation exposure limits get forth for an uncontrolled environment. This equipment should be installed & operated with minimum distance 20cm between the radiator & your body.

FCC Warning

This device complies with part 15 of the FCC Rules. Operation is subject to the following two conditions:

- (1) This device may not cause harmful interference.
 - (2) this device must accept any interference received, including interference that may cause undesired operation.
- CAUTION: Changes or modifications not expressly approved by the party responsible for compliance could void the user's authority to operate the equipment.