

XERUN USER MANUAL

Brushless Electronic Speed Controller
XERUN XR10 STOCK SPEC G2

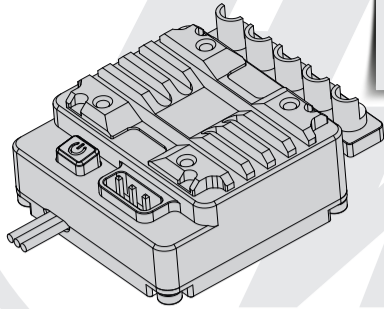

20240131

HW-SMA524ENG01-A1

01 Introduction



Thank you for purchasing this HOBBYWING product! Please read this declaration carefully before use, once you use the product, we will assume that you have read and agreed with all the content. Any improper use may cause personal injury and damage to the product and related devices, so please strictly follow the instruction during installation and use. Because we have no control over the use, installation, or maintenance of this product, no liability may be assumed for any damages or losses resulting from the use of the product. We do not assume responsibility for any losses caused by unauthorized modifications to our product. We have the right to modify our product design, appearance, features and usage requirements without notification. We, HOBBYWING, are only responsible for our product cost and nothing else as result of using our product. Regarding the possible semantic different between two different versions of declaration, for users in mainland China, please take the Chinese version as standard; for users in other regions, please take the English version as standard.

02 Warnings

- To avoid short circuits, ensure that all wires and connections are well insulated before connecting the ESC to related devices.
- Ensure all devices in the system are connected correctly to prevent any damage to the system.
- Read through the manuals of all power devices and chassis and ensure the power configuration is rational before using this unit.
- Please use a soldering iron with the power of at least 60W to solder all input / output wires and connectors.
- Stop usage once the casing of the ESC exceeds 90°C / 194°F as this may cause damage to both the ESC and motor. Hobbywing recommends setting the "ESC Thermal Protection" to 105°C / 221°F (this refers to the internal temperature of the ESC).
- The battery must be disconnected after use. There is a small draw even when the system is off, and will eventually fully drain the battery. This may cause damage to the ESC, and will NOT BE COVERED UNDER WARRANTY.

03 Features

- 3 select-to-use profiles applicable to 1/10 RC car racing.
- Separate PRG/FAN port is able to power an external fan for maximize cooling performance or connect a LCD program box or OTA Programmer to the ESC.
- Variable frequency regulation of PWM & brake frequencies allows users to precisely regulate the driving & braking forces (of the motors).
- Multiple protections: low-voltage cutoff protection, ESC and motor thermal protection, and fail safe (throttle signal loss protection), reverse polarity protection (the external standard capping will still be damaged if battery reversal occurs).
- Data logging for recording the maximum ESC/motor temperature, motor RPM, and others in real time.
- Firmware upgrade via Hobbywing multifunction LCD G2/Pro program box or OTA Programmer (item sold separately).

04 Specifications

Model	XERUN XR10 STOCK SPEC G2
Cont./Peak Current	100A/500A
Motor Type	Sensored / Sensorless Brushless Motors
Applications	Stock Class of 1/10 Touring Car and Buggy Racing, 1/10 Drift
Motor Limit	With 2S LiPo: > 10.5T
LiPo/NiMH Cells	2S LiPo(Only)
BEC Output	6V/7.4V Adjustable, Continuous Current of 5A (Switch-mode)
Size/Weight	34.8x30x13.8mm / 63g(w/ wires)
Programming Port	PRG/FAN Port

05 Connections

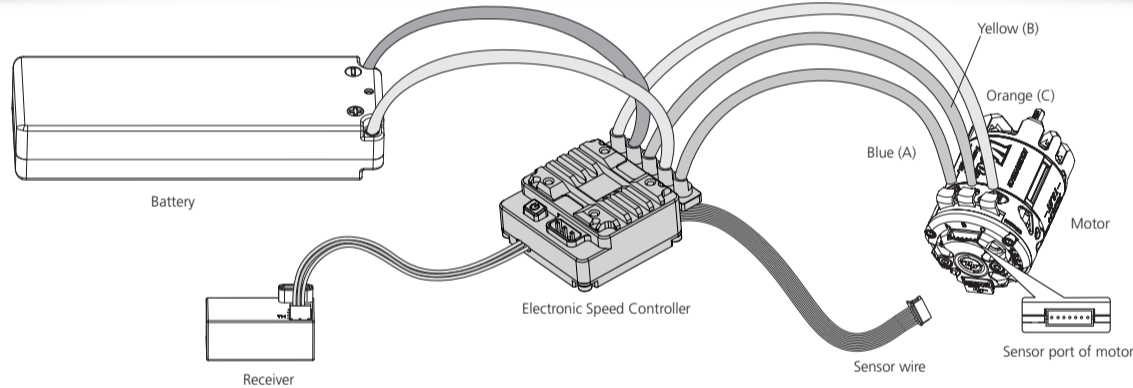

This is an extremely powerful brushless motor system. For your safety and the safety of those around you, we strongly recommend removing the pinion gear attached to the motor before performing calibration and programming functions with this system. It is also advisable to keep the wheels in the air when you turn on the ESC.

1. Motor Connection

- The motor wiring is different between the sensed and the sensorless; please only follow the introductions below.
- Sensored Motor Connection**
Sensored motor connection MUST connect A from the ESC to A on the motor, B to B, and C to C, with the sensor harness connected any variation of the motor to ESC connections may cause damage.
 - Sensorless Motor Connection**
Users do not need to be worried in regards to the connectivity with the A/B/C (ESC and motor) as there is no polarity. You may find it necessary to swap two wires if the motor runs in reverse.

2. Receiver Connection

The throttle control cable on the ESC has to be plugged into the throttle (TH) channel on the receiver. The throttle control cable has an output voltage of 6V / 7.4V to the receiver and steering servo, please do not supply additional power to the receiver, otherwise the esc may be damaged. If additional power is required, disconnect the red wire on the throttle plug from the ESC.

3. Battery Connection

Proper polarity is essential. Please ensure positive (+) connects to positive (+), and negative (-) connects to negative (-) when plugging in the battery! When reverse polarity is applied to the ESC from the battery, the external standard capping will be damaged.

06 ESC Setup

1 Set the Throttle Range - ESC Calibration Process

Begin using your ESC by calibrating with your transmitter. We strongly recommend Hobbywing users to use the "Fail Safe" function on the radio system and set (F5) to "Output Off" or "Neutral Position". Example of calibrating Neutral range and Endpoint.

Release the ON/OFF button once the LED flashes.

- Turn on the transmitter, ensure all parameters (D/R, Curve, ATL) on the throttle channel are at default (100%). For transmitter without LCD, please turn the knob to the maximum, and the throttle "TRIM" to 0. Please also turn the corresponding knob to the neutral position. **This step can be skipped if the radio's settings are default.**
- Start by turning on the transmitter with the ESC turned off but connected to a battery. Holding the "ON/OFF" button, the RED LED on the ESC starts to flash (the motor beeps at the same time), and then release the ON/OFF button.
Note: Beeps from the motor may be low sometimes, and you can check the LED status instead.

Press the ON/OFF button. The Green LED flashes once and motor emits "Beep" tone.

Press the ON/OFF button. The Green LED flashes three times and motor emits "Beep-Beep" tone.

- Set the neutral point, the full throttle endpoint and the full brake endpoint.
 - Leave transmitter at the neutral position, press the "ON/OFF" button, the GREEN LED flashes 1 time and the motor beeps 1 time to accept the neutral position.
 - Pull the throttle trigger to the full throttle position, press the "ON/OFF" button, the GREEN LED blinks 2 times and the motor beeps 2 times to accept the full throttle endpoint.
 - Push the throttle trigger to the full brake position, press the "ON/OFF" button, the GREEN LED blinks 3 times and the motor beeps 3 times to accept the full brake endpoint.
- The motor can be started 3 seconds after the ESC/Radio calibration is complete.

2 Power On/Off

Short press the power button to turn on the ESC in the off state, and long press the power button to turn off the ESC.

Attention! 1. After the esc operates at a high load, the temperature of the aluminum casing is very high, for safety, we suggest letting the esc cool naturally for one or two minutes before pressing the button to shut down, or using the "Remote Off" function to shut down (when the parameter "Remote Off" is set to "Enabled", the throttle trigger maintains full brake for 6 seconds, the esc will be turned off automatically).

2. To prevent accidental shutdown in racing, pressing the power button cannot shut down the esc while the motor is running, if there is an emergency, battery plugs can be pulled out to turn off the ESC.

3 Programmable Items

Section	Item	Programmable Items		Parameter Values												
General Setting	1A	Running Mode	Forward with Brake	Forward/ Reverse with Brake	Forward and Reverse											
	1B	Max. Reverse Force	25%	50%	75%	100%										
	1C	Cutoff Voltage	Disabled	Auto (3.5V/Cell)	3.0~7.4V Adjustable (Step: 0.1V)											
	1D	ESC Thermal Protection	Disabled	105°C/221°F	125 C/257°F											
	1E	Motor Thermal Protection	Disabled	105°C/221°F	125 C/257°F											
	1F	BEC Voltage	6V	7.4V												
	1G	Remote Off	Disabled	Enabled												
	1H	Motor Rotation	CCW	CW												
	1I	Phase-AC Swap	Disabled	Enabled												
	Throttle Control	2A	Throttle Rate Control	1~30 Adjustable (Step: 1)												
		2B	Throttle Curvature	-10~10 Adjustable (Step: 1)	Customized											
2C		Neutral Range	3%~10% Adjustable (Step: 1%)													
2D		Initial Throttle Force	1~15 Adjustable (Step: 1)													
2E		Coast	0%~15% Adjustable (Step: 0%)													
2F		PWM Drive Frequency	1K	2K	4K	8K	12K	16K	24K	32K	Customized					
2G		Softening Value	0~30° Adjustable (Step: 1°)													
2H		Softening Range	0%	10%	20%	25%	30%	35%	40%	45%	50%	55%	60%	65%	70%	75%
2I		RPM Limit	Unlimited						1000RPM~8800RPM Adjustable (Step: 1000RPM)							
Brake Control		3A	Drag Brake Force	0%~100% Adjustable (Step: 1%)												
	3B	Drag Brake Rate	Auto			1~20 Adjustable (Step: 1)										
	3C	Drag Brake Frequency	0.5K			1~16K Adjustable (Step: 1K)										
	3D	Max. Brake Force	0%~100% Adjustable (Step: 1%)													
	3E	Brake Rate Control	1~20 Adjustable (Step: 1)													
	3F	Brake Curvature	-10~10 Adjustable (Step: 1)	Customized												
	3G	Brake Frequency	0.5K	1K	2K	4K	8K	12K	16K	Customized						

Note: The above is the parameter table corresponding to the factory firmware of the esc, mainly used for Zero Timing(Blinky) competitions.

1A. Running Mode

Option 1: Forward with Brake

Racing mode. It has only forward and brake functions.

Option 2: Forward/ Reverse with Brake

This option is known to be the "training" mode with "Forward/ Reverse with Brake" functions. The vehicle only brakes on the first time you push the throttle trigger to the reverse/brake position. If the motor stops when the throttle trigger return to the neutral position and then re-push the trigger to reverse position, the vehicle will reverse, if the motor does not completely stop, then your vehicle won't reverse but still brake, you need to return the throttle trigger to the neutral position and push it to reverse again. This method is for preventing vehicle from being accidentally reversed.

Option 3: Forward and Reverse

The motor will reverse immediately when the throttle trigger is pushed to reverse position. This mode is generally used in special vehicles.

1B. Max. Reverse Force

The reverse force of the value will determine its speed. For the safety of your vehicle, we recommend using a low amount.

1C. Cutoff Voltage

Sets the voltage at which the ESC lowers or removes power to the motor in order to either keep the battery at a safe minimum voltage (for LiPo batteries). The ESC monitors the battery voltage all the time, it will immediately reduce the power to 50% (in 2 seconds) and cut off the output 40 seconds later when the voltage goes below the cutoff threshold. The RED LED will flash a short, single flash that repeats (☆, ☆, ☆) to indicate the low-voltage cutoff protection is activated.

Option 1: Disabled

The ESC does not cut the power off due to low voltage. We do not recommend using this option when you use any LiPo battery as you will irreversibly damage the product. You need to select this option when you are using a NiMH pack.

Option 2: Auto

The ESC calculates the corresponding cutoff voltage for the battery shall be 7.0V.

Option 3: Customized

The customized cutoff threshold is a voltage for the whole battery pack (adjustable from 3.0V to 7.4V).

1D. ESC Thermal Protection

The output from the ESC will be cut off with the value you have preset.

The GREEN LED flashes (☆, ☆, ☆) when the ESC temperature reaches to the preset value. The output will not resume until the ESC temperature gets down.

Warning! Please do not disable this function unless you're in a competition. Otherwise the high temperature may damage your ESC and even your motor.

1E. Motor Thermal Protection

The GREEN LED flashes (☆☆, ☆☆☆, ☆☆☆) when the motor temperature reaches to the preset value. The output will not resume until the motor temperature gets down.

Warning! Please do not disable this function unless you're in a competition. Otherwise the high temperature may damage your motor and even your ESC. For non-Hobbywing motor, the ESC may get this protection activated too early/late because of the different temperature sensor inside the motor. In this case, please disable this function and monitor the motor temperature manually.

1F. BEC Voltage

BEC Voltage can be set to 6V or 7.4V. Most servos will operate on 6V. If you are using a servo that can support 7.4V the setting can be changed.

1G. Remote Off

Option 1: Enabled

Users can simply push and hold the brake trigger for 6 seconds. This option allows the user to turn off the ESC without pushing the ON/OFF button switch.

Option 2: Disabled

Users must turn off the ESC by pressing the ON/OFF switch button from the ESC.

1H. Motor Rotation/Direction

With the motor shaft faces you (the rear end of the motor is away from you), increase the throttle input, the motor (shaft) will rotate in the CCW/CW direction if the "Motor Rotation / Direction" set to "CCW/CW". Generally, the vehicle runs forward when the motor (shaft) rotates in the CCW direction. However, some vehicles only run forward when the motor rotates in the CW direction due to the different chassis design. In that case, you only need to set the "Motor Rotation/Direction" to "CW".

1I. Phase-AC Swap

If the A/C wire of ESC connect to A/C wire of motor with crossed way (A wire of ESC connects to C wire of motor, C wire of ESC connects to A wire), set this item as Enable.

Warning! When #A/#B/#C wire of ESC connect to #A/#B/#C wire of motor correspondingly, do not set to Enable. Otherwise it will damage the ESC and motor.

2A. Throttle Rate Control

This item is used to control the throttle response. The higher the throttle rate, the more aggressive the throttle will be applied. A suitable rate can help driver to control the vehicle properly during the starting-up process. Generally, you can set it to a high value to have a quick throttle response if you are proficient at throttle control.

2B. Throttle Curvature

This parameter is used to set the throttle curve. The larger the curvature setting, the stronger the throttle output in the previous stage; the smaller the curvature setting, the softer the throttle output in the previous stage. As shown in the schematic diagram of the curve on the right.

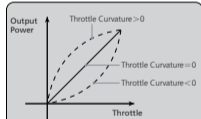

2C. Neutral Range

As not all transmitters have the same stability at "neutral position", please adjust this parameter as per your preference. You can adjust to a bigger value when this is required.

2D. Initial Throttle Force

It also called as minimum throttle force. You can set it according to wheel tire and traction. If the ground is slippery, please set a small throttle force. Some motors have strong cogging effect with lower FDR, if there is any cogging with very light throttle input, you can try to increase the initial throttle force.

2E. Coast

This function allows the motor to naturally and smoothly reduce rpm/speed, and the vehicle will not experience sudden deceleration during the throttle release process. The higher the value, the stronger the "coasting" feeling.

What is COAST?

When a vehicle has a larger final drive ratio, the tendency of having a "drag" feel is higher. The "COAST" technology is to allow the car to roll (coast) even when the final drive ratio is high. The Coast function brings better and smoother control feeling to racers. Some drivers will refer to this to the traditional brushed motors.

Note: The Coast setting will not work if the drag brake is not set to 0%.

2F. PWM Drive Frequency

The acceleration will be more aggressive at the initial stage when the drive frequency is low; a higher drive frequency is smoother but this will create more heat to the ESC. If set this item to "Customized", then the PWM frequency can be adjusted to a variable value at any 0-100% throttle input, Please choose the frequencies as per the actual test results of your vehicles.

2G. Softening Value

It allows users to fine-tune the bottom end, change the driving feel, and maximize the driving efficiency at different track conditions. The higher the "Softening Value", the softer the bottom end. Sometimes drivers may feel the power of the bottom end is too aggressive. Little throttle input usually brings too much power to the car and make it hard to control at the corners, this HOBBYWING's solution to help bottom end traction.

2H. Softening Range

It's the range to which "Softening Value" starts and ends. If set to 30% then the softening range will be from 0 throttle to 30% throttle.

2I. RPM Limit

It is used to set the max. RPM value of the motor. Set corresponding values according to competition rules.

Note: The RPM limit value here corresponds to a 2-pole motor. If a 4-pole motor (such as a Jstcock Handout motor) is used, it needs to be divided by 2 to obtain the corresponding mechanical rpm value. For example, using a Jstcock Handout 13.5T (3200KV) motor, if you want to limit the rpm to 22000rpm (mechanical rpm), you need to set the RPM limit value to: 22000*2=44000

3A. Drag Brake

It is the braking power produced when releasing from full speed to neutral position. This is to simulate the slight braking effect of a neutral brushed motor while coasting. It's not recommended for buggy and monster truck.

(Attention! Drag brake will consume more power and heat will be increased, use it cautiously.)

3B. Drag Brake Rate

This parameter is used to control the speed of the drag-brake response. Setting a suitable value can improve the drag braking effect of the vehicle, thus, improving drivability to suit each user. The value can be adjusted up to 20 levels. Increasing the value will result in a greater drag brake effect. The other "Auto" option is available as well to choose from. "Auto" will intelligently adjust the drag brake acceleration according to the current speed. The faster the current speed/rpm, the smaller the drag brake rate, vice versa.

3C. Drag Brake Frequency

The brake force will be larger if the frequency is low; you will get a smoother brake force when the value is higher. Please choose the frequencies as per the actual test results of your vehicles.

3D. Max. Brake Force

This ESC provides proportional braking function; the braking effect is decided by the position of the throttle trigger. It sets the percentage of available braking power when full brake is applied. Large amount will shorten the braking time but it may damage your pinion and spur.

3E. Brake Rate Control

It's adjustable from 1 to 20 (step: 1), the lower the brake rate, the more limit on the brake response. A suitable rate can aid the driver to brake his vehicle correctly. Generally, you can set it to a high value to have a quick brake response.

3F. Brake Curvature

This parameter is used to set the brake curve. The larger the curvature setting, the stronger the brake in the previous stage; the smaller the curvature setting, the softer the brake in the previous stage. As shown in the schematic diagram of the curve on the right.

3G. Brake Frequency

The brake force will be larger if the frequency is low; you will get a smoother brake force when the value is higher. If set this item to "Customized", then the brake frequency can be adjusted to a variable value at any 0-100% throttle input, Please choose the frequencies as per the actual test results of your vehicles.

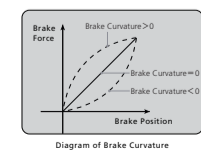

Section	Item	Programmable Items				Parameter Values													
General Setting	1A	Running Mode		Forward with Brake	Forward/ Reverse with Brake	Forward and Reverse													
	1B	Max. Reverse Force		25%	50%	75%	100%												
	1C	Reverse Delay		0-5S Adjustable (Step: 0.5S)															
	1D	Cutoff Voltage		Disabled	Auto (3.5V/Cell)			3.0~7.4V Adjustable (Step: 0.1V)											
	1E	ESC Thermal Protection		Disabled	105°C/221°F			125 C /257°F											
	1F	Motor Thermal Protection		Disabled	105°C/221°F			125 C /257°F											
	1G	BEC Voltage		6V	7.4V														
	1H	Remote Off		Disabled	Enabled														
	1I	Motor Rotation		CCW	CW														
	1J	Phase-AC Swap		Disabled	Enabled														
	Throttle Control	2A	Throttle Rate Control		1~30 Adjustable (Step: 1)														
2B		Throttle Curvature		-10~-10 Adjustable (Step: 1)	Customized														
2C		Neutral Range		3%~10% Adjustable (Step: 1%)															
2D		Initial Throttle Force		1~15 Adjustable (Step: 1)															
2E		Coast		0%~15% Adjustable (Step: 0)															
2F		PWM Drive Frequency		1K	2K	4K	8K	12K	16K	24K	32K	40K	48K	Customized					
2G		Softening Value		0~30° Adjustable (Step: 1°)															
2H		Softening Range		0%	10%	20%	25%	30%	35%	40%	45%	50%	55%	60%	65%	70%	75%		
Brake Control	3A	Drag Brake Force		0%~100% Adjustable (Step: 1%)															
	3B	Drag Brake Rate		Auto			1~20 Adjustable (Step: 1)												
	3C	Max. Brake Force		0%~100% Adjustable (Step: 1%)															
	3D	Brake Rate Control		1~20 Adjustable (Step: 1)															
	3E	Brake Curvature		-10~-10 Adjustable (Step: 1)	Customized														
	3F	Brake Frequency		0.5K	1K	2K	4K	8K	12K	16K	20K	24K	Customized						
Timing	4A	Boost Timing		0~64° Adjustable (Step: 1°)															
	4B	Boost Timing Activation		RPM			Auto												
	4C	Boost Start RPM		500~3500RPM (Step: 500RPM)															
	4D	Boost End RPM		3000~6000RPM (Step: 500RPM)															
	5A	Turbo Timing		0~64° Adjustable (Step: 1°)															
	5B	Turbo Delay		Instant	0.05s	0.1s	0.15s	0.2s	0.25s	0.3s	0.35s	0.4s	0.45s	0.5s	0.6s	0.7s	0.8s	0.9s	1.0s
	5C	Turbo Increase Rate		1deg/0.1s	2deg/0.1s	3deg/0.1s	5deg/0.1s	8deg/0.1s	12deg/0.1s	16deg/0.1s	20deg/0.1s	25deg/0.1s	30deg/0.1s	Instant					
	5D	Turbo Decrease Rate		1deg/0.1s	2deg/0.1s	3deg/0.1s	5deg/0.1s	8deg/0.1s	12deg/0.1s	16deg/0.1s	20deg/0.1s	25deg/0.1s	30deg/0.1s	Instant					

Note: The above is the parameter table corresponding to the update of Boost firmware (firmware name suffix "_Boost"), mainly used for Open Stock competitions or drift car. And the following is the explanation of the added parameter items, for other similar parameter items, please refer to the content below the previous parameter table.

1C. Reverse Delay :

This parameter is used to adjust and set the delay time when the reverse output is being applied; When the motor is at a standstill, the reverse output will be activated once the delay time of the value is reached.

4A. Boost Timing

It is effective within the whole throttle range; it directly affects the car speed on straightaway and turns. The ESC adjusts the timing dynamically as per the RPM (when "Boost Timing Activation" set to "RPM") or throttle amount (when "Boost Timing Activation" set to "Auto") in the operation. The Boost Timing is not constant but variable.

4B. Boost Timing Activation

Option 1: RPM

In RPM mode, the ESC adjusts the Boost Timing dynamically as per the motor speed (RPM). The actual Boost Timing is 0 when the RPM is lower than the Boost Start RPM. The Boost Timing changes as per the RPM when the RPM change is between the Boost Start RPM and the Boost End RPM. For example, if the Boost Timing is set to 5 degrees and the Boost Start RPM is 10000, the Boost End RPM is 15000. The Boost Timing corresponds to different RPM is shown below. When the RPM is higher than the Boost End RPM, the actual Boost Timing is the value you had previously set.

RPM (Motor Speed)	<10000	10001-11000	11001-12000	12001-13000	13001-14000	14001-15000	>15000
Actual Boost Timing	0 Degree	1 Degree	2 Degrees	3 Degrees	4 Degrees	5 Degrees	5 Degrees

Option 2: Auto

In Auto mode, the ESC adjusts the Boost Timing dynamically as per the throttle amount. Only at full throttle, the actual Boost Timing is the value you had previously set.

4C. Boost Start RPM

This item defines the RPM at which Boost Timing is activated. For example, when the Boost Start RPM is set to 5000, the ESC will activate the corresponding Boost Timing when the RPM goes above 5000. The specific value is determined by the Boost Timing and the Boost End RPM you had previously set.

4D. Boost End RPM

This item defines the RPM at which Boost Timing (you specifically set) is applied. For example, when Boost Timing is set to 10 degrees and the Boost End RPM to 15000, the ESC will activate the Boost Timing of 10 degrees when the RPM goes above 15000. The ESC will adjust the Boost Timing accordingly as per the actual RPM when the RPM goes below 15000.

5A. Turbo Timing

This item is adjustable from 0 degree to 64 degrees, the corresponding turbo timing (you set) will initiate at full throttle. It's usually activated on long straightaway and makes the motor unleash its maximum potential.

5B. Turbo Delay

When "TURBO DELAY" is set to "INSTANT", the Turbo Timing will be activated right after the throttle trigger is moved to the full throttle position. When other value(s) is applied, you will need to hold the throttle trigger at the full throttle position (as you set) till the Turbo Timing initiates.

5C. Turbo Increase Rate

This item is used to define the "speed" at which Turbo Timing is released when the trigger condition is met. For example, "3 degs/0.1sec" refers to the Turbo Timing of 3 degrees that will be released in 0.1 second. Both the acceleration and heat is higher when the "Turbo increase rate" is of a larger value.

5D. Turbo Decrease Rate

After the Turbo Timing is activated and the trigger condition turns to not be met (i.e. vehicle slows down at the end of the straightaway and gets into a corner, full throttle turns to partial throttle, the trigger condition for Turbo Timing turns to be not met), if you disable all the Turbo Timing in a moment, an obvious slow-down like braking will be felt and cause the control of vehicle to become bad. If the ESC can disable the Turbo Timing at some "speed", the slow-down will be linear and the control will be improved.

Warning! Boost Timing & Turbo Timing can effectively improve the motor efficiency; they are usually used in competitions. Please take some time to read this manual and then set these two items carefully, monitor the ESC & motor temperatures when you have a trial run and then adjust the Timing and FDR accordingly as aggressive Timings and FDR may cause your ESC or motor to be burnt.

4 Preset Modes

In order to make one firmware applicable to all different racing conditions, there are three "easy-to-select" preset modes (as shown below). Users are able to change the settings of the modes provided (and rename those modes) as per the control feel, track, and etc. For example, the name can be changed from "1/10 On-road" to "TITC2019_Stock_13.5T" to indicate the race was ran with a 13.5T motor at 2019 TITC. This can be saved for future reference as well.

Preset Modes for Different Racing:

Mode #	Modes/Profiles	Applications
1	1/10 On-Road	Zero Timing(Blinky) class of 1/10 touring car racing
2	1/10 Buggy-2WD	Zero Timing(Blinky) class of 1/10 2WD buggy racing
3	1/10 Buggy-4WD	Zero Timing(Blinky) class of 1/10 4WD buggy racing

"_Boost" Firmware:

Mode #	Modes/Profiles	Applications
1	1/10 On-Road	Stock class of 1/10 touring car racing
2	1/10 Off-Road	Stock class of 1/10 buggy racing
3	1/10 2WD-Drift	1/10 drift racing

5 ESC Programming

1. Program your ESC with a multifunction LCD program box pro

Connect the interface marked with "- + a" on the esc to the interface marked with "ESC" on the program box using a separate programming cable(a cable with JR plugs at both ends included in the program box packaging), then connect the esc to the battery and turn it on. Click on **【Parameter Settings】** to set the esc.

2. Using the OTA Programmer for parameter settings

Insert the programming cable of the OTA Programmer into the programming interface of the esc, and use your phone to install the HW Link APP to set the esc.

3. Read the running data of esc

- Click on the **【Data record】** on the homepage of the LCD box pro to read the five extreme values of the highest temperature of the esc, the highest temperature of the motor, the maximum current, the lowest voltage of the battery, and the highest rpm of the motor during the operation of the esc.
- By using the OTA Bluetooth module, you can view the five extreme values recorded above, real-time data, and historical data (curve chart) under the **【Data Log】** menu in the HW LINK App on your phone.

4. Upgrade of firmware for esc

- Using the LCD box pro or OTA programmer, download and install the HW LINK App on your phone, click on the **【Firmware Update】** button on the APP homepage to upgrade the firmware of the esc.
- Connect to the computer through the LCD box pro, download and install Hobbywing USB LINK software on the computer, and use this software to upgrade the firmware for esc.

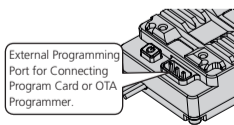

6 Factory Reset

• Restore the default values with a multifunction LCD program box pro

After connecting the program box to the ESC, Click on **【Parameter Settings】** and select the **【Reset Parameters】** to restore the factory settings.

• Restore the default values with a OTA Programmer (8 HW Link App)

After connecting the OTA Programmer to the ESC, open the HOBBYWING HW Link App on your smart phone, select "Parameters" followed by "Factory Reset" to reset the ESC.

07 Explanation for LED Status

1. The throttle is in neutral zone

- In Non-rpm limit mode, the red LED flashes rapidly.
- In the RPM limit mode, setting different RPM limit values results in different LED flashing phenomena, the specific rules are: the number of times the green light flashes represents ten thousand digits of the RPM limit value you set, and the number of times the red light flashes represents one thousand digits of the RPM limit value you set. For example, if the RPM limit is set to 25000, the green light will flash twice and then the red light will flash five times. This cycle; If the RPM limit is set to 40000, the green light will flash four times and cycle. And so on.
- If the esc is upgraded to the "_Boost" firmware and there is a setting for Boost or Turbo timing, the red LED will remain on and not flash.

2. The throttle is in non-neutral zone

- The GREEN LED blinks when your vehicle runs forward. The GREEN LED turns solid when pulling the throttle trigger to the full (100%) throttle.
- The GREEN LED blinks when you brake your vehicle. The GREEN LED turns solid when pushing the trigger to the full brake and setting the "maximum brake force" to 100%.
- The GREEN LED blinks when you reverse your vehicle.

3. When Some Protection is Activated

- The RED LED flashes a short, single flash and repeats "☆☆, ☆, ☆" indicating the low voltage cutoff protection is activated.
- The GREEN LED flashes a short, single flash and repeats "☆☆, ☆, ☆" indicating the ESC thermal protection is activated.
- The GREEN LED flashes a short, double flash and repeats "☆☆☆, ☆☆☆, ☆☆☆" indicating the motor thermal protection is activated.
- The RED & GREEN LEDS flash a short, single flash and repeats "☆☆, ☆, ☆" at the same time indicating the drive mode has been automatically switched to sensorless mode from sensored mode because of abnormal sensor signal when pairing the ESC with a sensored motor.

08 Trouble Shooting

Trouble	Possible Causes	Solutions
The ESC was unable to start the status LED, the motor, after it was powered on.	1. No power was supplied to the ESC; 2. The ESC switch was damaged.	Check if all ESC & battery connectors have been well soldered or firmly connected.
After power on, the RED LED flashes and the motor does not work.	The throttle cable of the esc is connected incorrectly or the throttle is not at the neutral position.	1. Plug the throttle cable into the throttle channel (CH2) by referring to relevant mark shown on your receiver. 2. Calibrate the esc and radio.
The vehicle is going in the reversed direction when the forward throttle is applied.	The default/popular motor rotation direction does not match your car frame.	Adjust the parameter "Motor Rotation".
The motor suddenly stopped or significantly reduced the output in operation.	1. The receiver was influenced by some foreign interference; 2. The ESC entered the LVC protection; 3. The ESC entered the thermal shutdown protection.	1. Check all devices and try to find out all possible causes, and check the transmitter's battery voltage; 2. The RED LED keeps flashing indicating the LVC protection is activated, please replace your pack; 3. The GREEN LED keeps flashing indicating the thermal protection is activated, please let your ESC cool down before using it again.
The motor stuttered but couldn't start.	1. The (ESC-to-motor) wiring order was incorrect 2. Some soldering between the motor and the ESC was not good; 3. The ESC was damaged (some MOSFETS were burnt).	1. Check if the wiring order is A-A, B-B, and C-C 2. Check all soldering points, please re-solder if necessary; 3. Contact the distributor for repair or other customer service.
The vehicle could run forward (and brake), but could not reverse.	1. The throttle neutral position on your transmitter was actually in the braking zone; 2. Set the "Running Mode" improperly; 3. The ESC was damaged.	1. Recalibrate the throttle neutral position; 2. Set the "Running Mode" to "Fwd/Rev with Brk"; 3. Contact the distributor for repair or other customer service.
The motor got stuck or stopped when increasing the throttle during the starting-up process.	1. Poor discharging capability of the pack; 2. The RPM of the motor was too high, or the FDR was too low; 3. The Throttle Rate Control is set too high.	1. Change another pack with great discharging capability. 2. Change a low-speed motor, or increase the FDR; 3. Set the Throttle Rate Control to a low level.
The RED & GREEN LEDS on the ESC flashed rapidly at the same time when the throttle trigger was at the neutral position.	(When pairing with a sensored motor) the ESC automatically switched to sensorless mode when it detected incorrect signal from Hall sensor.	1. Check if the sensor cable is loose or poor contact issue exists; 2. Hall sensor inside the motor is damaged.