

# MP 54\*20"

## 技术参数 Specification

产品型号 Model	MP 54*20"	单支重量 Weight	420±15g
主要材质 Material of Props	碳纤维+环氧树脂 Carbon fiber+Epoxy resin	表面工艺 Surface technics	哑光磨砂 Matte abrazine
存储温度 Storage temperature	-10°C~35°C	使用环境温度 Operating Temperature	-40°C~65°C
最佳转速范围 Recommended speed range	1400~2400 RPM	存储湿度 Storage humidness	≤85%
极限拉力 Ultimate tension	70 kg	常用拉力范围 Recommended thrust	15~50 kg
直桨/折叠桨 Folding/unfolding	直桨 unfolding	推荐搭配电机 Recommended motors of hobbywing	M13825

## 尺寸图 Dimension figure

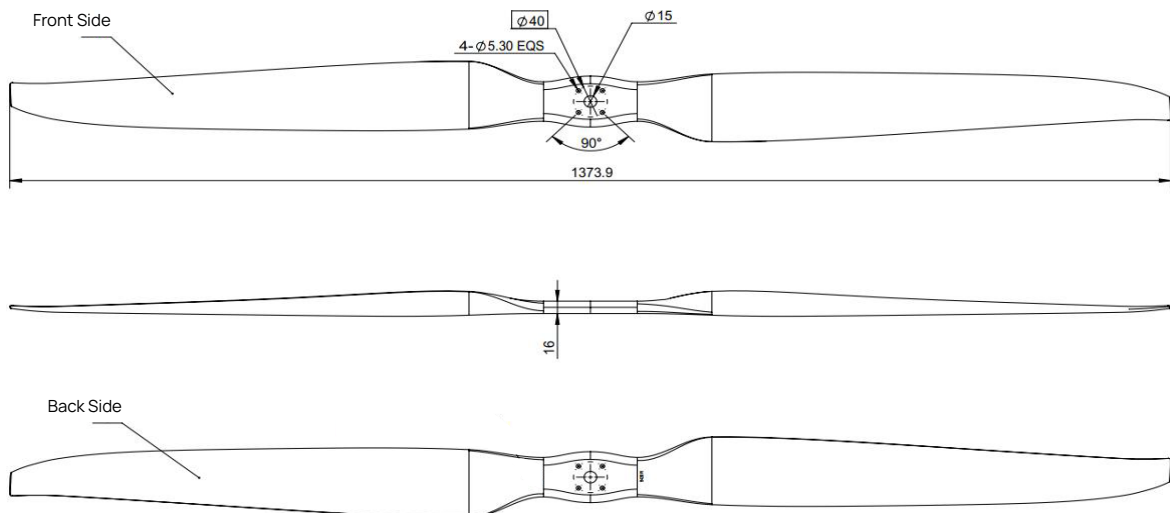

## 转速、拉力、扭矩测试数据 Speed, thrust and torque test data

