

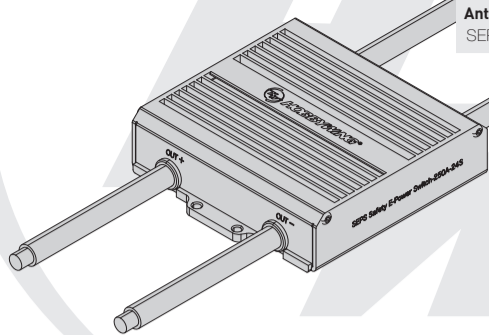

Thank you for your purchase. Please read the following statement carefully before use. Once used, it is considered to be an acceptance of all the contents. Please follow the manual instructions carefully during the installation. Modification may result in personal injury and product damage. We reserve the rights to update the design and performance of the product without notice.



Anti-Spark Module · USER MANUAL
SEPS Safety E-power Switch-250A



20260319

01 Introduction

The anti-spark module has anti-spark function when connect it to power supply, which effectively protect plugs, power supply and electronic devices. The aluminium alloy dentate heat sink design of shell can better dissipate heat and reduce working temperature. Internal glue filling and packaging technology. The waterproof grade up to IP67.

02 Features

- The anti-spark module can be connected to 250A current continuously under the condition of 5m/s wind speed dissipation heat.
- The 5 m/s wind speed heat dissipation and anti-spark module can be connected to use unlimited times under normal service life, which is more advantageous than anti-spark plug.
- The anti-spark module completely eliminates sparks by controlling MOSFET switching and delaying power-on.
- Optional electronic switch can be used to control on-off .

03 Specifications

Product name	Input voltage	Max Current (good heat dissipation)	Volume (with screw holes)	Weight
24S-250A-SEPS	54V-104.4V	250A	98.0*90.0*24.0mm	518.5±5g

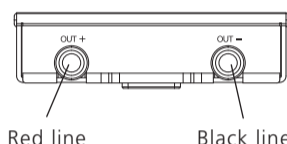
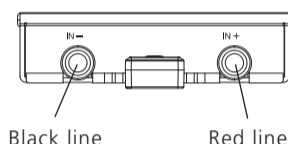
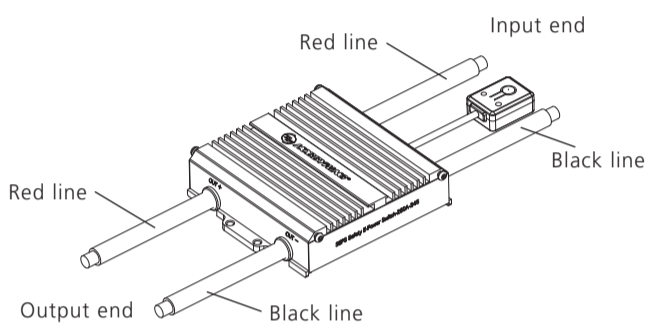

Input end

Output end

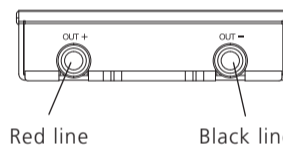
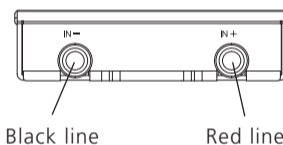
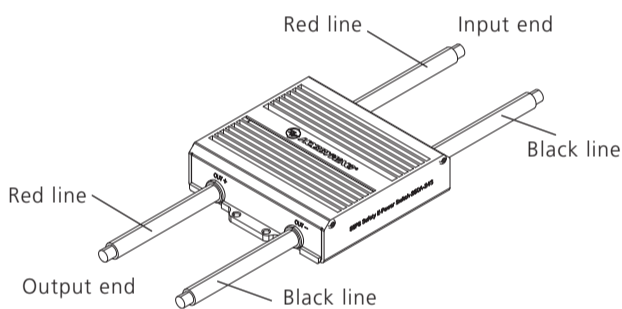

Input end

Output end

04 Connection mode

Note: Please use high-power welding equipment to weld power line, and ensure the reliable grounding of the welding equipment.

Wiring diagram:

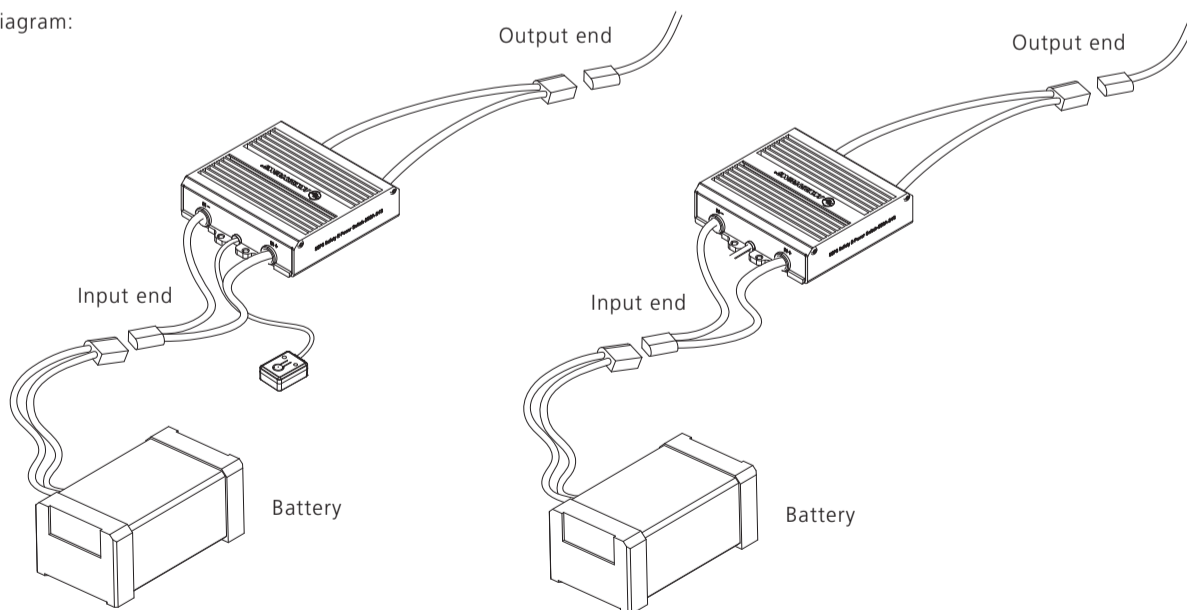

First step:

Weld plug for input end and output end of anti-spark module to connect power supply and load equipment.

Second step:

Firstly connect the output end of anti-spark module with distributor circuit or ESC load (Must connect anti-spark module and load first, then connect anti-spark module and battery can realize anti-spark function.)

Third step:

After all preliminary connections and pre-flight preparations are complete, finally plug the battery into the SEPS to power the aircraft; it can then take off at any time. If the optional switch-equipped version is used, tap once and then press and hold until the LED on the switch stays on continuously—only then is power-on successful.

Note:

1. The SEPS draws a small standby current (< 200 mA); when not in use it must be physically disconnected from the battery.
2. On the no-switch version, powering up twice within any 5-second window can still produce a spark.
3. Mount the module next to the battery or on the exterior of the airframe where airflow can cool it—this is the recommended method. If the module is run continuously its case temperature can reach 110 °C; reduce power or it may overheat and shut down.