

01 Introduction

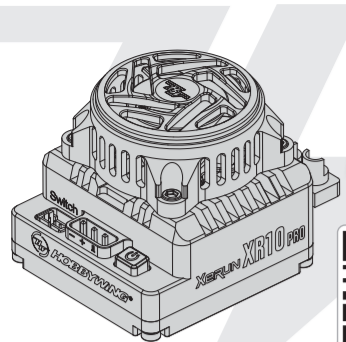

XERUN
USER MANUAL
Brushless Electronic Speed Controller
XERUN XR10 Pro G3
XERUN XR10 Pro G3-X



Thank you for purchasing this HOBBYWING product! Please read this instruction manual carefully before use, once you use the product, we will assume that you have read and agreed with all the content. Brushless power systems can be very dangerous and any improper use may cause personal injury and damage to the product and related devices, so please strictly follow the instruction during installation and use. Because we have no control over the use, installation, or maintenance of this product, no liability may be assumed for any damages or losses resulting from the use of the product. We do not assume responsibility for any losses caused by unauthorized modifications to our product. We have the right to modify our product design, appearance, features and usage requirements without notification. We, HOBBYWING, are only responsible for our product cost and nothing else as result of using our product. With the possible differences between the two version of the manual, for users in mainland China, please take the Chinese version as standard; for users in other regions, please take the English version as standard.



HW-SMPS4-00L02

02 Warnings

- To avoid short circuits, ensure that all wires and connectors are well insulated before connecting the ESC to related devices.
- Ensure all devices in the system are connected correctly to prevent any damage to the system.
- Read the manuals of all the items being used in the build. Ensure gearing, setup, and overall install is correct and reasonable.
- Please use a soldering iron with the power of at least 60W to solder all input/output wires and connectors.
- Do not hold the vehicle in the air and rev it up to full throttle, as rubber tires can "expand" to extreme size or even explode and cause serious injury.
- Stop usage if the casing of the ESC exceeds 90°C / 194°F as this may cause damage to both the ESC and motor. Hobbywing recommends setting the "ESC Thermal Protection" to 105°C / 221°F (this refers to the internal temperature of the ESC).
- The battery must be disconnected after use. There is a small draw even when the system is off, and will eventually fully drain the battery. This may cause damage to the ESC, and will NOT BE COVERED UNDER WARRANTY.

03 Features

- 3 select-to-use profiles applicable to all 1/10th RC car racing.
- Internal electronic key switch for long service life, high reliability, and the external switch port for connecting an external switch (not included in the packaging box, purchase separately) is applicable to different installations.
- Separate programming port is able to power an external fan or connect a LCD Program Box Pro or OTA Programmer to the ESC.
- Variable frequency regulation of PWM & brake frequencies allows users to precisely regulate the driving & braking forces (of the motors).
- Softening function (innovative by HOBBYWING) for power delivery tuning and better driving efficiency.
- Disc Brake mode (innovative by HOBBYWING), with smoother and stronger brake.
- Multiple protections: low-voltage cutoff protection, ESC and motor thermal protection, and fail safe (throttle signal loss protection).
- The ESC has a built-in data recording module, which eliminates the need to constantly connect to the OTA Bluetooth module. After running, connecting to the OTA Bluetooth module allows users to view various running data through the HW Link mobile app.
- Firmware upgrade via Hobbywing LCD Program Box Pro or OTA Programmer (item sold separately).

04 Specifications

Model	XERUN XR10 Pro G3	XERUN XR10 Pro G3-X
Cont./Peak Current	160A/1200A	
Motor Type	Sensored / Sensorless Brushless Motors	
Applications	1/10th Touring car & Buggy racing, 1/10th Drift, F1, Rally	
Motor Limit	Touring Car: >=4.5T, Buggy: >=5.5T, 3650 (540) size 2-pole motor	
LiPo/NiMH Cells	2S LiPo(Only 2S)	
BEC Output	5-7.4V Adjustable, Continuous Current of 6A (Switch-mode)	
Cooling Fan	Powered by the stable BEC voltage	
Size	41.0x33.6x30.3mm (w/fan&fan Shroud, the terminal board extends 6.0 mm from the case)	
Weight	93g (w/ wires)	101.5g (w/ wires)
Programming Port	Independent programming interface	
Reverse Polarity Protection	Yes	No

05 Connections

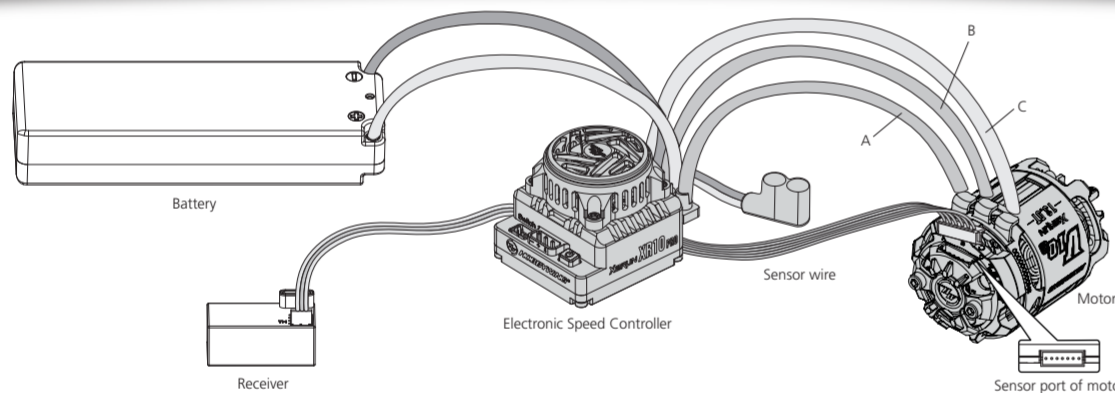

This is an extremely powerful brushless motor system. For your safety and the safety of those around you, we strongly recommend removing the pinion gear attached to the motor before performing calibration and programming functions with this system. It is also advisable to keep the wheels in the air when you turn on the ESC.

- Motor Connection**
Sensored motor connection MUST connect A from the ESC to A on the motor, B to B, and C to C, with the sensor wire connected any variation of the motor to ESC connections may cause damage.
Note: 1) If the motor direction is reversed, change the parameter item "Motor Rotation" to achieve the correct setting.
2) If it is necessary to connect the # A of the esc to the # C of the motor due to layout wiring, please make sure to set the parameter item "Phase-AC Swap" to "Enabled".
- Receiver Connection**
The throttle control cable on the ESC has to be plugged into the throttle (TH) channel on the receiver. The throttle control cable has an output voltage of 5-7.4V to the receiver and steering servo, no separate battery can be connected to the receiver. Otherwise, your ESC may be damaged. If additional power is required, disconnect the red wire on the throttle plug from the ESC.
- 3. Brake Connection**
Proper polarity is essential. Please ensure positive (+) connects to positive (+), and negative (-) connects to negative (-) when plugging in the battery!
Note: The standard version XR10 Pro G3 esc has reverse polarity protection, so reverse connection will not damage the esc, but conventional external capacitor pack will be damaged. The XR10 Pro G3-X esc does not have reverse polarity protection, so reverse connection will damage the esc.

06 ESC Setup

1 ESC/Radio Calibration

Begin using your ESC by calibrating with your transmitter. We strongly recommend Hobbywing users to use the "Fail Safe" function on the radio system and set (FS) to "Output OFF" or "Neutral Position". Example of calibrating Neutral range and Endpoint.

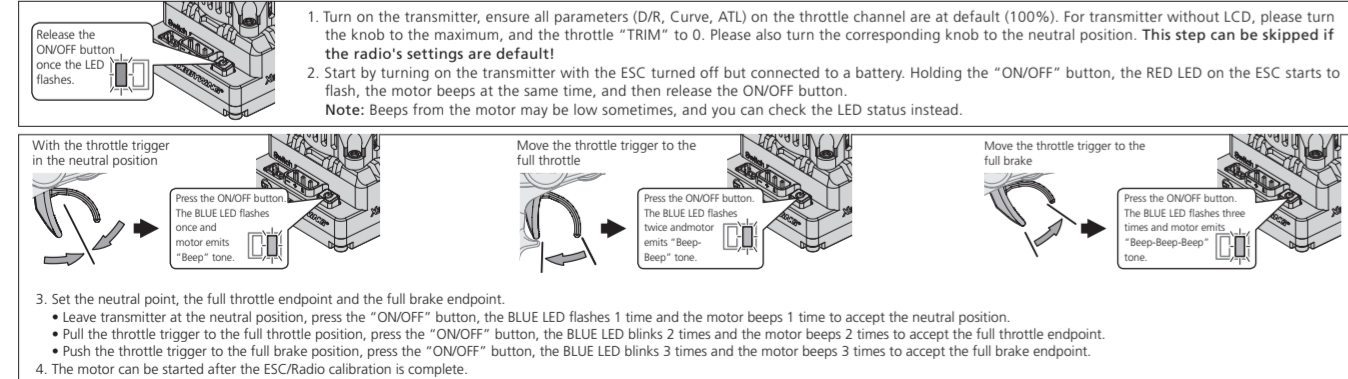

2 Power On/Off

In the off state, short press the switch button to turn on the esc. Long press the power button to turn off the esc.
Attention:
1. To prevent accidental shutdown, clicking the switch button cannot shut down the esc while it is running; it can only be turned off when the motor stops running, when unable to shut down in an emergency, please disconnect the battery directly, and if not in use for a long time, please disconnect the battery.
2. After running, the temperature of the aluminum casing may be very high, to prevent finger burns during shutdown, we suggest letting the esc cool naturally for one or two minutes before pressing the button to shut down. If an external switch has already been installed, it can be used to shut down. You can also use the transmitter to shut down the esc (when the "Auto Off" parameter is set to remote off, the esc will automatically shut down after the throttle trigger hold the full brake for 6 seconds).

3 Programmable Items

Section	Item	Programmable Items		Parameter Values	
General Setting	1A	Settings Mode*	Basic	Advanced	
	1B	Running Mode*	Forward with Brake	Forward/Reverse with Brake	Forward and Reverse
	1C	Max. Reverse Force*	25%	50%	75%
	1D	Cutoff Voltage*	Disabled	Auto (3.5V/Cell)	3.0-7.4V Adjustable (Step: 0.1V)
	1E	ESC Thermal Protection*	Disabled	105°C/221 F	125°C/257 F
	1F	Motor Thermal Protection*	Disabled	105°C/221 F	125°C/257 F
	1G	BEC Voltage*			5.0V-7.4V Adjustable (Step:0.1V)
	1H	Smart Fan*	Disabled	Enabled	
	1I	Auto Off*	Disabled	Remote Off	Delay 5 Minutes
	1J	Sensor Mode	Full Sensored	Sensored/Sensorless Hybrid	Delay 10 Minutes
Throttle Control	1K	Motor Rotation	CCW	CW	
	1L	Phase-AC Swap	Disabled	Enabled	
	2A	Throttle Rate Control*			1-30 Adjustable (Step: 1)
	2B	Throttle Curvature	-10~10 (Step: 1)	Customized	
	2C	Neutral Range			3%-10% Adjustable (Step: 1%)
	2D	Initial Throttle Force			1-15 Adjustable (Step: 1)
	2E	Coast			0-15% Adjustable (Step: 1%)
	2F	PWM Drive Frequency*	2K-32K(Step: 1)	Customized	
	2G	Softening Value*			0-30* Adjustable (Step: 1*)
	2H	Softening Range*	0% 10% 20% 25% 30% 35% 40% 45% 50% 55% 60% 65% 70% 75%		
Brake Control	2I	Freewheeling*	Disabled	Enabled	
	2J	RPM Decrease Rate			1-20(Step: 1)
	3A	Drag Brake Force*			0%-100% Adjustable (Step: 1%)
	3B	Drag Brake Rate*	Auto		1-20 Adjustable (Step: 1)
	3C	Drag Brake Frequency	0.5K		1K-16K (Step: 1K)
	3D	Max. Brake Force*			0%-150% Adjustable (Step: 1%)
	3E	Brake Rate Control	Auto		1-20 Adjustable (Step: 1)
	3F	Brake Control	Linear	Linear-S	Traditional Disc Brake
	3G	Disc Brake Softening			0-20(Step: 1)
	3H	ABS Force			0-20% (Step: 1%)
Timing	3I	Brake Curvature	-10~10 (Step:1)	Customized	
	3J	Brake Frequency	0.5K		1K-16K (Step: 1K)
	4A	Boost Timing*			0-64* Adjustable (Step: 1*)
	4B	Boost Timing Activation	Auto	RPM	Throttle
	4C	Boost Start RPM			500-35000RPM (Step: 500RPM)
	4D	Boost End RPM			3000-60000RPM (Step: 500RPM)
	4E	Boost Start TH			1%-90% (Step: 1%)
	4F	Boost End TH			10%-100% (Step: 1%)
	5A	Turbo Timing*			0-64* Adjustable (Step: 1*)
	5B	Turbo Delay*	Instant 0.05s 0.1s 0.15s 0.2s 0.25s 0.3s 0.35s 0.4s 0.45s 0.5s 0.6s 0.7s 0.8s 0.9s 1.0s		
5C	Turbo Increase Rate*	Instant		1deg/0.1s-32deg/0.1s (Step:1deg/0.1s)	
5D	Turbo Decrease Rate*	Instant		1deg/0.1s-32deg/0.1s (Step:1deg/0.1s)	
Configuration	6A	Motor Poles*			2-10 (Step: 2)
	6B	Gear Ratio*			2.0-12.0 (Step: 0.1)
	6C	Tire Diameter*			30mm-150mm (Step: 1)
	6D				

Note: The PWM Drive Frequency, Brake Frequency, Brake Control, Boost Timing, Turbo Timing and relevant items will be invalid (that's item 2F, 3I, 3F and items from 4A to 5D) when Sensor Mode (item 1J) is set to "Sensored/Sensorless Hybrid".

- 1A. Settings Mode**
In Basic mode, only some basic and commonly parameter items are displayed, see the items marked with "*" in the parameter table, while in Advanced mode, all parameter items will be displayed.
- 1B. Running Mode**
Option 1: Forward with Brake
Racing mode. It has only forward and brake functions.
Option 2: Forward/Reverse with Brake
This option is known to be the "racing" mode with "Forward/Reverse with Brake" functions. The vehicle only brakes on the first time you push the throttle trigger to the reverse/fairly position. If the motor stops when the throttle trigger return to the neutral position and then re-push the trigger to reverse position, the vehicle will reverse. If the motor does not completely stop, then your vehicle won't stop but still brake you need to return the throttle trigger to the neutral position and push it to reverse again. This method is for preventing vehicle from being accidentally reversed.
Option 3: Forward and Reverse
The motor will reverse immediately when the throttle trigger is pushed to reverse position. This mode is generally used in special vehicles.
- 1C. Max. Reverse Force**
The reverse force of the value will determine its speed. For the safety of your vehicle, we recommend using a low amount.
- 1D. Cutoff Voltage**
Sets the voltage at which the ESC lowers or removes power to the motor in order to either keep the battery at a safe minimum voltage (for LiPo batteries). The ESC monitors the battery voltage all the time, it will reduce the power and then cut the output about 40 seconds later when the voltage goes below the cutoff threshold. The RED LED will flash a short, single flash that repeats (1, 2, 3) to indicate the low-voltage cutoff protection is activated. Please set the "Cutoff Voltage" to "Disabled" or customize this item if you are using NiMH batteries.
Option 1: Disabled
The ESC does not cut the power off due to low voltage. We do not recommend using this option when you use any LiPo battery as you will irreversibly damage the product. You need to select this option when you are using a NiMH pack.
Option 2: Auto
The ESC calculates the corresponding cutoff voltage for the battery shall be 7.0V(2S LiPo).
Option 3: Customized
The customized cutoff threshold is a voltage for the whole battery pack (adjustable from 3.0V to 7.4V).
- 1E. ESC Thermal Protection**
After enabling this function, when the temperature of the ESC reaches the set value, it will reduce the power and then cut off the output about 40 seconds later. The Blue LED will flash a short, single flash that repeats (1, 2, 3) to indicate the over-heat protection is activated.
Warning! Please do not disable this function unless you're in a competition. Otherwise the high temperature may damage your ESC and even your motor.
- 1F. Motor Thermal Protection**
After enabling this function, when the temperature of the motor reaches the set value, it will reduce the power and then cut off the output about 40 seconds later. The Blue LED will flash a short, double flash that repeats (1, 2, 3) to indicate the over-heat protection is activated.
Warning! Please do not disable this function unless you're in a competition. Otherwise the high temperature may damage your motor and even your ESC. For non-Hobbywing motor, the ESC may get this protection activated too early/late because of the different temperature sensor inside the motor. In this case, please disable this function and monitor the motor temperature manually.
- 1G. BEC Voltage**
BEC voltage can be adjusted between 5.0-7.4V. Set a reasonable value according to the working voltage of the servo.
- 1H. Smart Fan**
This esc has a fan control function. If this item is set to "Disabled", the fan will continue to run once the ESC is powered on; if this item is set to "Enabled", the fan will start running after the internal temperature of the esc exceeds 50°C/122°F.
- 1I. Auto Off**
When this option is set to "Disabled", the automatic shutdown function is disabled and manual shutdown is required. When set to "Remote Off", simply hold the throttle trigger in the maximum brake position for about 6 seconds, and the ESC will automatically shut down. When set to "Delay 5 Minutes", if the throttle trigger is at the neutral position for 5 minutes without action, the ESC will automatically shut down. When set to "Delay 10 Minutes", if the throttle trigger is at the neutral position for 10 minutes without action, the ESC will automatically shut down.
- 1J. Sensor Mode**
Option 1: Full Sensored
The power system will work in the "sensored" mode at all times. The efficiency and drivability of this mode is at the highest.
Option 2: Sensored/Sensorless Hybrid
The ESC operates the motor in sensored mode during the low-speed start-up process, followed by switching to operating the motor in the "sensorless" mode. This dual drive mode is applicable to 4WD SCT vehicles using 4 pole motors.
Warning! Do not select the option 1 if you are using a non-Hobbywing matching motor, or 4 pole sensored motor, otherwise you may damage your ESC and motor.
- 1K. Motor Rotation/Direction**
Used to set the rotation direction of the motor. Due to differences in chassis frame structure, it is possible for the car to reverse when the throttle is applied to forward. In this case, you can solve it by adjusting this item.
- 1L. Phase-AC Swap**
If the AC wire of ESC connect to AC wire of motor with crossed way (A wire of ESC connects to C wire of motor, C wire of ESC connects to A wire), set this item as Enable.
Warning! When A#/B#/C wire of ESC connect to A#/B#/C wire of motor correspondingly, do not set to Enable. Otherwise it will damage the ESC and motor.

- 2A. Throttle Rate Control**
This item is used to control the throttle response. The higher the throttle rate, the more aggressive the throttle will be applied. A suitable rate can help driver to control the vehicle properly during the starting-up process.
- 2B. Throttle Curvature**
This parameter is used to set the throttle curve. The larger the curvature setting, the stronger the throttle output in the previous stage; the smaller the curvature setting, the softer the throttle output in the previous stage. As shown in the schematic diagram of the curve on the right.
- 2C. Neutral Range**
This parameter adjusts the range of the throttle neutral area to suit different transmitters and driver habits. If the neutral position of the transmitter is unstable, causing the car to move slowly forward or backward, or have difficulties calibrating the neutral range, the setting can be raised to correct the issue.
- 2D. Initial Throttle Force**
This is also called as minimum throttle force. You can set it according to wheel tire and traction. If the ground is slippery, please set a small throttle force. Some motors have strong cogging effect with lower FRD. If there is any cogging with very light throttle input, you can try to increase the initial throttle force.
- 2E. Coast**
This function allows the motor to naturally and smoothly reduce rpm/speed, and the vehicle will not experience sudden deceleration during the throttle release process. The higher the value, the stronger the "coasting" feeling.
What is COAST?
When a vehicle has a larger final drive ratio, the tendency of having a "drag" feel is higher. The "COAST" technology is to allow the car to roll (coast) even when the final drive ratio is high. The Coast function brings better and smoother control feeling to racers. Some drivers will refer to this to the traditional brushed motors.
Note: The Coast setting will not work if the drag brake is not set to 0%.
- 2F. PWM Drive Frequency**
The acceleration will be more aggressive at the initial stage when the drive frequency is low; a higher drive frequency is smoother but this will create more heat to the ESC. If set this item to "Customized", then the PWM frequency can be adjusted to a variable value at any 0-100% throttle input. Please choose the frequencies as per the actual test results of your vehicles.
- 2G. Softening Value**
It allows users to fine-tune the bottom end, change the driving feel, and maximize the driving efficiency at different track conditions. The higher the "Softening Value", the softer the bottom end. Sometimes drivers may feel the power of the bottom end is too aggressive. Little throttle input usually brings too much power to the car and make it hard to control at the corners, this is HOBBYWING's solution to help bottom end traction.
- 2H. Softening Range**
It's the range to which "Softening Value" starts and ends. If set to 30% then the softening range will be from 0 throttle to 30% throttle.
- 2I. Freewheeling**
When this function is enabled, it will slow down faster when releasing the throttle, provide better handling on the curve, and less heat under the same conditions.
- 2J. RPM Decrease Rate**
This refers to the speed of rpm change when reducing the throttle; the higher the value, the faster the change. If you want to achieve the experience of natural sliding when reducing the throttle like normal brushless power, this value needs to be set to a low level.
Note: This parameter only takes effect when the "Freewheeling" is set to "Enabled".
- 3A. Drag Brake**
It is the braking power produced when releasing from full speed to neutral position. This is to simulate the slight braking effect of a neutral brushed motor while coasting. It's not recommended for buggy and monster truck. (Attention! Drag brake will consume more power and heat will be increased, apply it cautiously.)

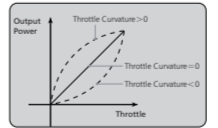

- 3B. Drag Brake Rate**
This parameter is used to control the response of the drag brake. The higher the setting value, the faster the drag brake. "Auto" will intelligently adjust the drag brake rate according to the current speed, the higher the current speed, the lower the drag brake rate.
- 3C. Drag Brake Frequency**
The drag brake force will be larger if the frequency is low, and you will get a smoother brake force when the value is higher. Please choose the frequencies as per the actual test results of your vehicles.
- 3D. Max. Brake Force**
This ESC provides proportional braking function; the braking effect is decided by the position of the throttle trigger. It sets the percentage of available braking power when full brake is applied. Large amount will shorten the braking time and it may damage your pinion and spur.
- 3E. Brake Rate Control**
This parameter is used to control the response of the brake. The higher the setting value, the faster the brake. A suitable rate can aid the driver to brake his vehicle correctly. Generally, you can set it to a high value to have a quick brake response.
- 3F. Brake Control**
Option 1: Linear
Hobbywing has recommended using this mode under all circumstances. The braking effect is a bit weaker in this mode than in Traditional brake mode, but it's easy to control and brings great control feel.
Option 2: Linear-S
This mode provides slightly softer braking compared to the "Linear" mode. If you find the braking force too strong or experience wheel lockup in Linear mode, you can switch to this mode.
Option 3: Traditional
This is the traditional brake mode, with slightly stronger brake force but not as smooth as Linear brake control.
Option 4: Disc Brake
This is an innovative braking method from HOBBYWING, the braking force is not affected by the motor speed, with better brake linearity and stronger brake force.
- 3G. Disc Brake Softening**
This parameter is used to soften the disc brake. If you feel that the braking force in the low speed range is too strong, you can set this parameter. The larger the value, the softer the disc brake.
Note: This parameter only takes effect when the "Brake Control" is set to "Disc Brake".
- 3H. ABS Force**
This parameter is used to set the brake force when the speed is relatively low, the higher the value, the greater the brake force. Setting this value appropriately according to the traction is beneficial for preventing wheel lockup and sliding, and it will help to control the vehicle when entering the corner.
Note: This parameter only takes effect when the "Brake Control" is set to "Disc Brake".
- 3I. Brake Curvature**
This parameter is used to set the brake curve. The larger the curvature setting, the stronger the brake in the previous stage; the smaller the curvature setting, the softer the brake in the previous stage. As shown in the schematic diagram of the curve on the right.
- 3J. Brake Frequency**
The brake force will be larger if the frequency is low; you will get a smoother brake force when the value is higher. Please choose the frequencies as per the actual test results of your vehicles.
Note: This parameter will take effect when the "Brake Control" is set to "Linear" or "Linear-S" or "Traditional".
- 4A. Boost Timing**
It is effective within the whole throttle range; it directly affects the car speed on straightaway and winding course. The ESC adjusts the timing dynamically according to the setting of the "Boost Timing Activation". The Boost Timing is not constant but variable.
- 4B. Boost Timing Activation**
Option 1: Auto
In Auto mode, the ESC adjusts the Boost Timing dynamically as per the throttle amount. Only at full throttle, the actual Boost Timing is the value you had previously set.
Option 2: RPM
In RPM mode, it is associated with the 4C and 4D parameter items. The actual Boost Timing is 0 when the RPM is lower than the Boost Start RPM. The Boost Timing changes as per the RPM when the RPM change is between the Boost Start RPM and the Boost End RPM. When the RPM is higher than the Boost End RPM, the actual Boost Timing is the value you had previously set.
Option 3: Throttle
In Throttle mode, it is associated with the 4E and 4F parameter items. When the actual throttle is lower than the "Boost Start TH", the actual Boost opening value is 0. When the throttle is between the "Boost Start TH" and "Boost End TH", Boost dynamically changes according to the current throttle. When the actual throttle is higher than the "Boost End TH", the actual Boost opening value is the Boost value you set.
- 4C. Boost Start RPM**
This item defines the RPM at which Boost Timing is activated. For example, when the Boost Start RPM is set to 5000, the ESC will activate the corresponding Boost Timing when the RPM goes above 5000. The specific value is determined by the Boost Timing and the Boost End RPM you had previously set.
- 4D. Boost End RPM**
This item defines the RPM at which Boost Timing (you specifically set) is applied. For example, when Boost Timing is set to 10 degrees and the Boost End RPM to 15000, the ESC will activate the Boost Timing of 10 degrees when the RPM goes above 15000. The ESC will adjust the Boost Timing accordingly as per the actual RPM when the RPM goes below 15000.
- 4E. Boost Start TH**
This is used to set the start throttle required to activate the Boost Timing. For example, when set to 10%, the Boost timing will only be activated when the throttle is above 10%.
- 4F. Boost End TH**
This is used to set the throttle amount required to relate all Boost Timing. For example, when set to 90%, the full Boost timing value will only be released when the throttle is above 90%. When the actual throttle is between the start throttle and the end throttle, it is dynamically allocated based on the Boost timing you set.
- 5A. Turbo Timing**
This item is adjustable from 0 degree to 64 degrees, the corresponding turbo timing (you set) will initiate at full throttle. It's usually activated on long straightaway and makes the motor unleash its maximum potential.
- 5B. Turbo Delay**
When "TURBO DELAY" is set to "INSTANT", the Turbo Timing will be activated right after the throttle trigger is moved to the full throttle position. When other value(s) is applied, you will need to hold the throttle trigger at the full throttle position (as you set) till the Turbo Timing initiates.
- 5C. Turbo Increase Rate**
This item is used to define the "speed" at which Turbo Timing is released when the trigger condition is met. For example, "3 deg/0.1sec" refers to the Turbo Timing of 3 degrees that will be released in 0.1 second. Both the acceleration and heat is higher when the "Turbo increase rate" is of a larger value.
- 5D. Turbo Decrease Rate**
After the Turbo Timing is activated and the trigger condition turns to not be met, it will slowly slow down at the end of the straightaway and gets into a corner, full throttle turns to partial throttle, the trigger condition for Turbo Timing turns to not met, if you disable all the Turbo Timing in a moment, an obvious slow-down like braking will be felt and cause the control of vehicle to become bad. If the ESC can disable the Turbo Timing at some "speed", the slow-down will be linear and the control will be improved.
Warning! Boost Timing & Turbo Timing can effectively improve the motor efficiency, they are usually used in competitions. Please take some time to read this manual and then set these two items carefully, monitor the ESC & motor temperatures when you have a trial run and then adjust the Timing and FRD accordingly as aggressive Timing and FRD may cause your ESC or motor to be burnt.
- 6A-6C. Configuration**
These settings are mainly used to set parameters related to the calculation the speed of vehicle. Please set them according to the actual configuration. After setting these items, the vehicle speed data can be viewed in the recorded data curve chart through the mobile app using the OTA Bluetooth module. Please note that the gear ratio is the final decelerate ratio (FRD) of the vehicle.

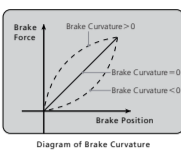

4 Preset Modes

In order to make one firmware applicable to all different racing conditions, there are three "easy-to-select" preset modes (as shown below). Users are able to change the settings of the modes provided (and rename those modes) as per the control feel, track, and etc. For example, the name can be changed from "1/10 On-Road" to "TIT2024_MOD_45" to indicate the race was run with a 4.5T motor at 2024 TITC. This can be saved for future reference as well.

Preset Modes for Different Racing:

Mode #	Modes/Profiles	Applications
1	Zero Timing	All Stock racing requiring users to use Zero timing (blinky) program on their ESCs.
2	1/10 On-Road	Open class of 1/10th touring car racing
3	1/10 Off-Road	Open class of 1/10th buggy racing

5 ESC Programming

- 1. Program your ESC with a multifunction LCD Program Box Pro**
Connect the interface marked with "+ + +" on the esc to the interface marked with "ESC" on the program box using a separate programming cable with J1R plugs at both ends included in the program box packaging), then connect the esc to the battery and turn it on. Click on "Parameter Settings" to set the esc.
- 2. Using the OTA Programmer for parameter settings**
Insert the programming cable of the OTA Programmer into the programming interface of the esc, and use your phone to install the HW Link APP to set the esc.
Set the running data of esc
1) Click on the "Data record" on the homepage of the LCD Box Pro to read the five extreme values of the highest temperature of the esc, the highest temperature of the motor, the maximum current, the lowest voltage of the battery, and the highest rpm of the motor during the operation of the esc.
2) By using the OTA Bluetooth module, you can view the five extreme values recorded above, real-time data, and historical data (curve chart) under the "Data Log" menu in the HW Link App on your phone. For extreme value data and historical record data (curve graph), there is no need to connect the OTA Bluetooth module to the ESC during running. It can be connected when viewing the data after the running.
Note: The XERUN XR10 Pro G3-X version has no current data for the ESC, and the value is displayed as 0.
- 3. Upgrade of firmware for esc**
1) Using the LCD box pro or OTA Programmer, download and install the HW Link App on your phone, click on the "Firmware Update" button on the APP homepage to upgrade the firmware of the esc.
2) Connect to the computer through the LCD box pro, download and install Hobbywing USB LINK software on the computer, and use this software to upgrade the firmware for esc.



6 Factory Reset

- Restore the default values with a multifunction LCD Program Box Pro
After connecting the program box to the ESC, click on "Parameter Settings" and select the "Reset Parameters" to restore the factory settings.
- Restore the default values with a OTA Programmer (& HW Link App)
After connecting the OTA Programmer to the ESC, open the HOBBYWING HW Link App on your smart phone, select "Parameters" followed by "Factory Reset" to reset the ESC.

07 Explanation for LED Status

- 1. During the Start-up Process**
 - The RED LED turns solid indicating the ESC doesn't detect any throttle signal or the throttle trigger is at the neutral position.
 - The BLUE LED flashes rapidly indicating the neutral throttle value stored on your ESC may be different from the current value stored on the transmitter. When this happens, re-calibrate the throttle range.
- 2. In Operation**
 - The RED LED turns on solid when the throttle trigger is in the throttle neutral zone. The RED LED will blink slowly to suitable for zero-timing/blinky racing rules if the total value of Boost Timing and Turbo timing is 0, and the softening value is set to 0 at the same time.
 - The BLUE LED blinks when your vehicle runs forward. The BLUE LED turns solid when pulling the throttle trigger to the full (100%) throttle endpoint.
 - The BLUE LED blinks when you brake your vehicle. The BLUE LED turns solid when pushing the throttle trigger to the full brake endpoint and setting the "maximum brake force" to 100%.
 - The BLUE LED blinks when you reverse your vehicle. The BLUE LED turns solid when pushing the throttle trigger to the full brake endpoint and setting the "reverse force" to 100%.
- 3. When Some Protection is Activated**
 - The RED LED flashes a short, single flash and repeats "1, 2, 3" indicating the low voltage cutoff protection is activated.
 - The BLUE LED flashes a short, single flash and repeats "1, 2, 3" indicating the ESC thermal protection is activated.
 - The BLUE LED flashes a short, double flash and repeats "1, 2, 3" indicating the motor thermal protection is activated.
 - The RED & BLUE LEDs flash a short, single flash and repeats "1, 2, 3" at the same time indicating the drive mode has been automatically switched to sensorless mode from sensored mode because of abnormal sensor signal when pairing the ESC with a sensored motor.

08 Trouble Shooting

Trouble	Possible Causes	Solutions
The ESC was unable to start the status LED, the motor, after it was powered on.	No power was supplied to the ESC.	Check if all ESC & battery connectors have been well soldered or firmly connected.