

# MFC 63x24

## Specification

Model	MFC 63x24	Total weight (Including propeller adapter)	990±10 g
Material of blade	Carbon fiber+Epoxy resin	Surface technics	Matte frosted
Material of Props adapter	Aluminium alloy	Operating temperature	-40°C~65 °C
Storage temperature	-10°C~35 °C	Storage humidness	≤85 %
Max thrust	80 kg	Recommended thrust	17~65 kg
Recommended RPM range	1200~2200 RPM	Max RPM	2460 RPM
Non-folding/Folding	Folding propeller	Recommended motors of HOBBYWING	X15

## Dimension Figure

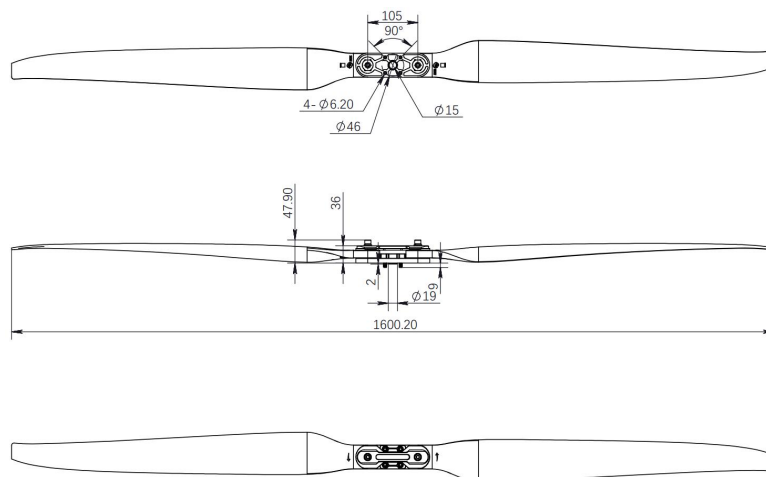

## Speed, thrust and torque test data

