

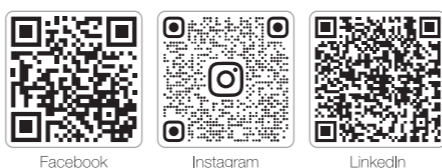

Thank you for purchasing this product! The brushless propulsion system is powerful. Improper use may result in personal injury or equipment damage. Therefore, we strongly recommend that you read this manual carefully before using the equipment and strictly follow the prescribed operating procedures. Under no circumstances shall the manufacturer be liable for damages caused by misuse or unauthorized modifications, including but not limited to compensating for incidental or indirect damages.

X9 Plus G2L is not designed for eVTOL and cannot be used for manned flights. eVTOL aircraft, please contact Hobbywing to or look for more professional eVTOL motors.



## 01 Introduction

The X9 Plus G2L brushless propulsion system is designed for applications in agriculture, education and training, logistics, fire fighting, surveying, inspection and other fields, with a single-axis rated load of 12-14kg and a maximum single-axis thrust of 28kg, and is adaptable to 45mm carbon fiber tube arms, making it suitable for various small and medium-sized drones. The waterproof rating of IPX6 ensures reliable operation in challenging environments. For heavy-loaded drones, the FOC driven algorithm of ESC based on PMSM system is optimized. This propulsion system supports both digital and analog throttle modes, which are of mutual redundancy and seamless switch. The product features power-on self-check, voltage anomaly protection, overcurrent protection, and stall protection. It utilizes HWCAN and DroneCAN dual communication protocols (i.e., Cyphal (UAVCAN)), making it compatible with most mainstream closed-source and open-source flight controllers, offering real-time data transmission. Additionally, the built-in fault storage and logging feature allows for fault data recording, and the OTA upgrade allows for propulsion system upgrade through the flight controller.

## 02 Precautions

- During usage, keep away from crowds, high-voltage power line, obstacles, etc. Make sure to comply with local laws and regulations, as well as safe flight standards.
- The propellers are designed for flat terrains, and are not suitable for plateaus. The normal operating altitude is below 2,000 meters. When above this altitude, use the corresponding high-altitude propellers or reduce the flight load. In hot summer weather, especially at noon, adjust the flight load appropriately based on the actual temperature.
- The propeller is made of carbon fiber reinforced nylon composite material, and is not suitable for coaxial use. Do not use this propeller for coaxial purposes.
- The most suitable propeller for this product is 43 \* 14" propeller. It is not recommended to use propellers from other models or manufacturers. It is recommended to use the official standard propeller.
- Avoid flying in extreme weather conditions such as strong winds, heavy rain, snow, fog, thunderstorms, sandstorms, or ice.
- Do not approach high-speed rotating propellers and motors to avoid injury.
- Do not perform indoor testing or flight with the propellers attached. For indoor testing, make sure to remove the propellers.
- Before trial use, check if all parts are in good condition. If any damage is found, contact the after-sales service for replacements.
- Before flight, check if the screws on the connecting structures are tightened and whether the motor is level. If necessary, fix the reserved holes on the motor mounting seat with rivets.
- The X9 Plus G2L propulsion system is compatible with circular tubes with an outer diameter of 45 mm.
- Use the recommended batteries. Do not use non-conforming batteries, such as those exceeding standard range or those with a low discharge rate. The product operates across a wide voltage range. The 12-14S Lithium-ion polymer battery is recommended, with an optimal voltage range of 44.4V-60.9V. If a 6S battery is used, the motor will rotate, but the lift will not meet actual requirements. It is only recommended for no-propeller testing.
- After each operation, flush the motor with water to keep it clean and tidy.
- The digital throttle must be used with a flight controller with a CAN throttle output. For related usage methods, contact the flight controller manufacturer.
- Do not modify this product (including changing it to a coaxial structure) without authorization. The manufacturer is not liable for damages caused by unauthorized modifications.
- Before takeoff, ensure that the single-axis hover thrust is within the rated load range. Overloading may cause the motor and ESC temperature to rise rapidly, which may lead to a crash.
- Do not disassemble the ESC or motor without authorization to avoid damaging the motor or affecting the ESC's protective capabilities.
- Use original parts for repairs and replacements. If any blade or propeller adapter is damaged, replace it immediately. The unique codes of the two blades are consistent. If one blade is damaged, replace both. For any damage to other parts, contact technical support or the drone manufacturer immediately.
- When using CAN digital throttle, it is recommended to set the idle throttle of the flight controller to 6%.

## 03 Propulsion Composition

- Motor \* 1pcs
- ESC \* 1pcs
- Propeller \* 1pcs
- Structure \* 1pcs
- Screws \* n
- LED set

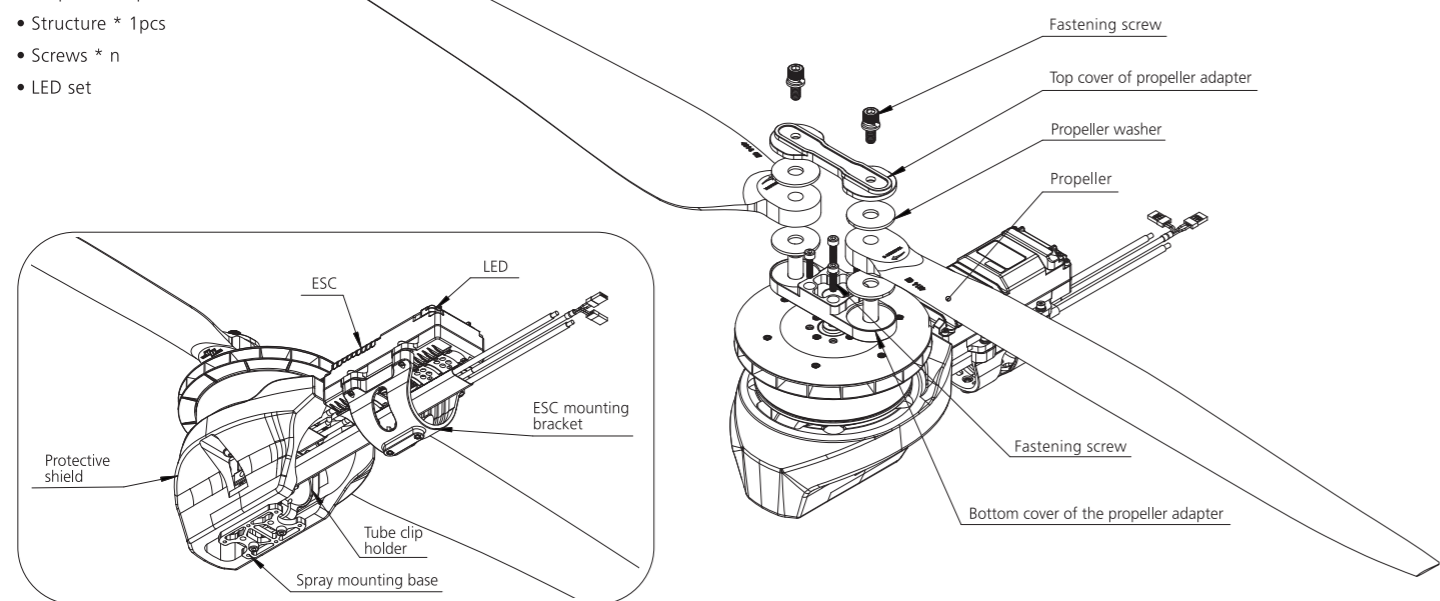

## 04 Dimensions

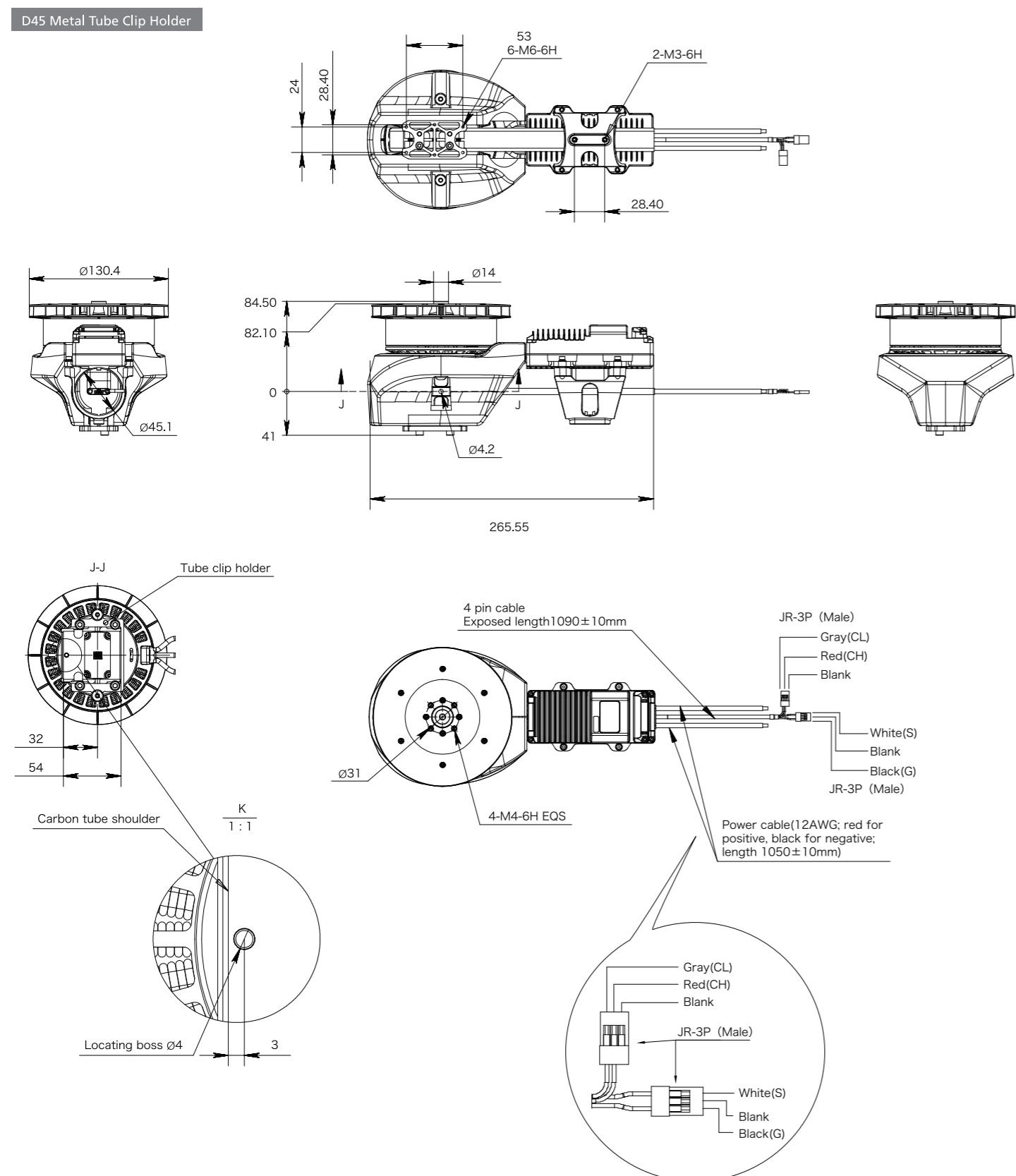

## Propeller Drawings

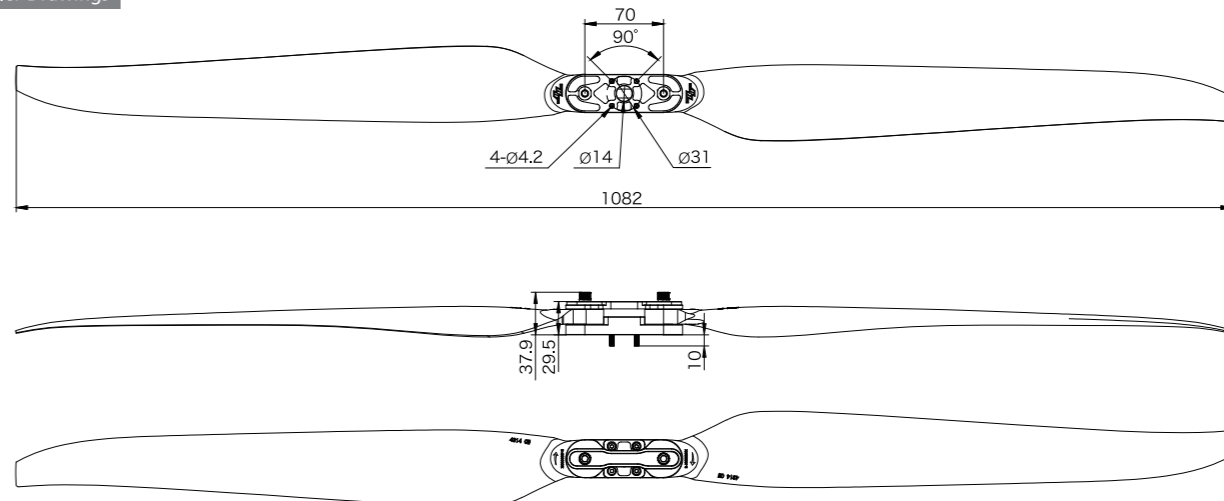

## 05 Propulsion Installation

### D45 Carbon Tube Pre-processing (Compatible with metal tube clip holder)

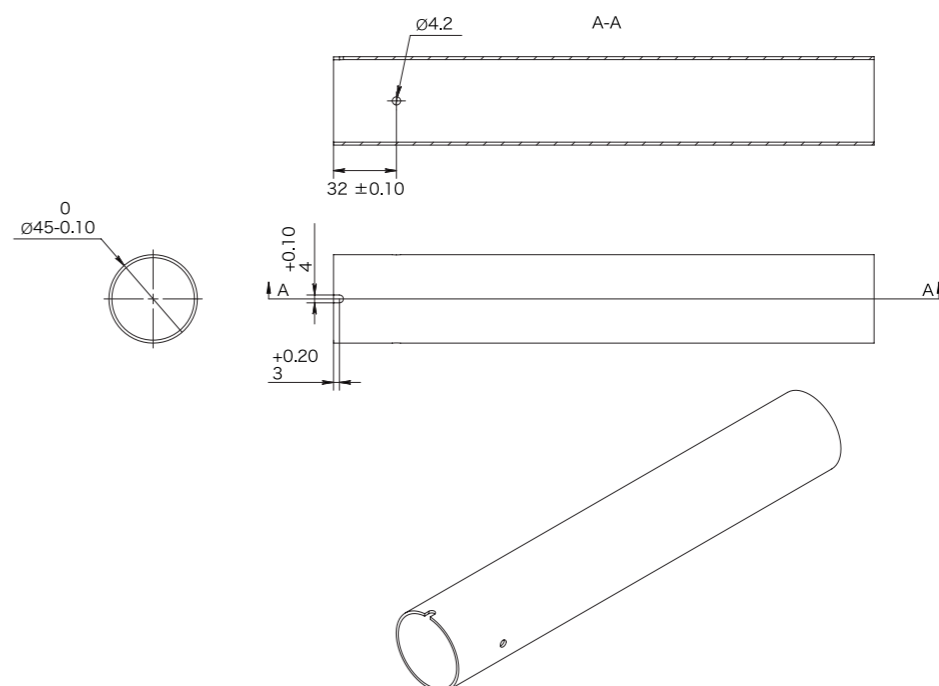

### Assemble Steps (for metal tube clip holder)

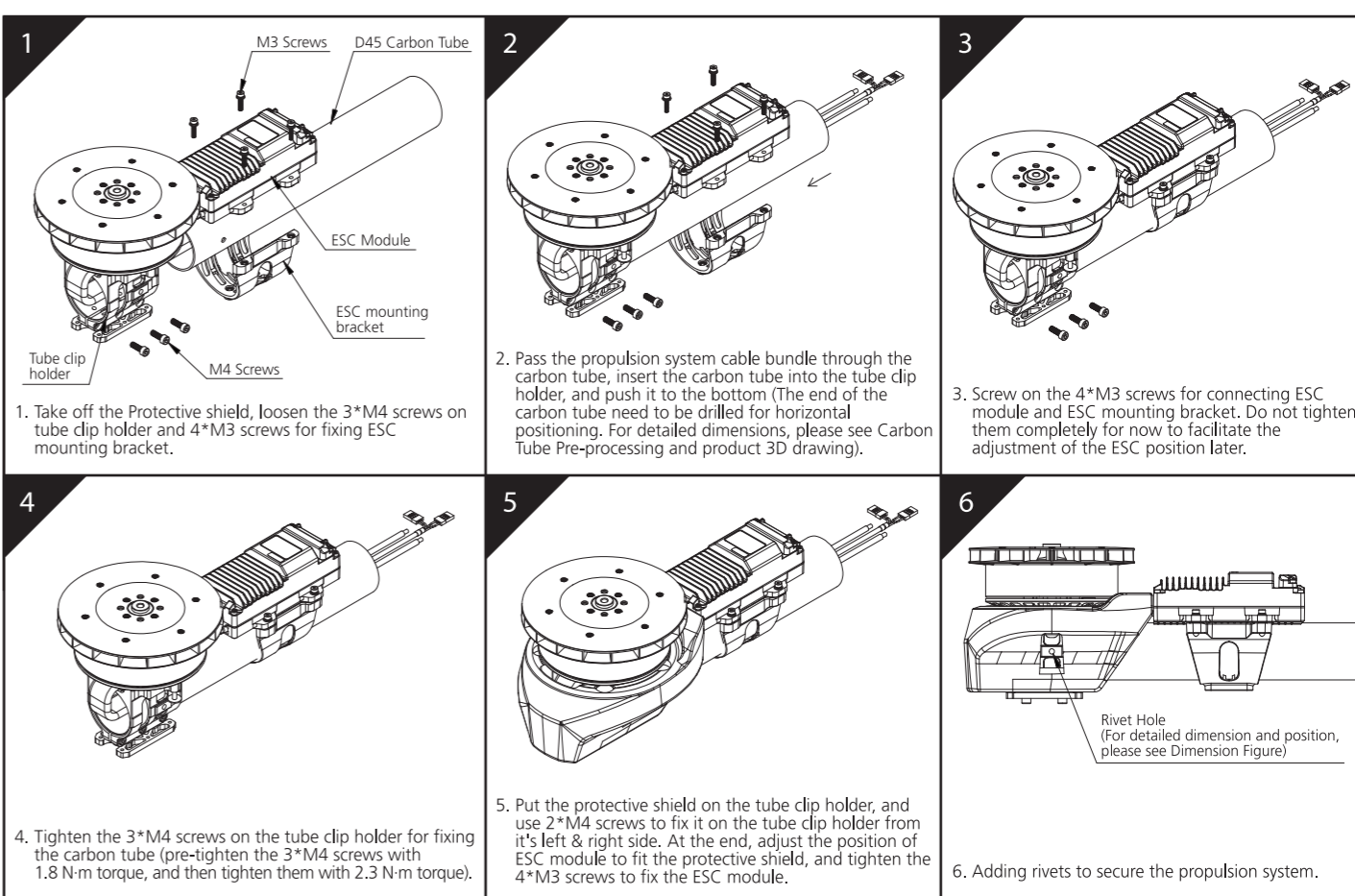

- Note:**
- Red and gray wires are for data output, firmware upgrade (can upgrade the ESC system), and digital throttle wire, respectively, using the CAN protocol. Red and gray, Red—CH, Gray—CL.
  - The black and white wires are for PWM throttle, black for the ground wire, and white for the PWM signal wire. The throttle cable must be connected to the corresponding motor control interface on the flight controller.

## 06 Specifications

**X9 Plus G2L**  
 Rated single-axis load: 12-14kg (sea level)  
 Maximum thrust: 28kg (sea level)  
 Rated voltage: 12S-48V/14S-54V  
 Lithium battery: 12-14S (maximum 63V)  
 Ambient temperature: -20~50°C  
 Compatible carbon tube diameter: 45mm  
 Total weight: 1852g\* (including propeller)  
 Ingress protection: IPX6  
 Recommended thrust range efficiency: 8.6-8.0g/W  
 Throttle source: PWM+CAN  
 Rated output power (Max continuous): 1440W  
 Rated current: 40A  
 Parameter adjustment function: Via software or transmitter  
 Power cable: Black and red 12AWG-1050 mm±10mm  
 Signal cable: 1090mm±10mm

**ESC**  
 Recommended lithium battery: 12-14S (LiPo)  
 Voltage range: 18-63V  
 Continuous current: 40A (non-confined ambient temperature <45°C)  
 Instantaneous current: 150A (non-confined ambient temperature <45°C)  
 PWM fixed throttle: 1,050-1,950µs  
 PWM throttle frequency: 50-500Hz  
 Throttle range calibration: Not supported  
 BEC: None  
 Fault storage: Supported  
 Logging time: Default 1h (Max 24h by changing Storage Interval)  
 Communication protocol: HWCAN + DroneCAN (i.e., Cyphal (UAVCAN))  
 CAN terminal resistor: None  
 CAN default baud rate: 500kbps  
 CAN sampling point: 83.3%  
 Pinout: Black—GND, White—Signal, Red—CAN High, Gray—CAN Low

**Motor**  
 Stator size: 96x20 mm  
 Size: Φ104x51.1 mm (Fan Φ130 mm)  
 KV value: 80 KV  
**Propeller**  
 Model: MFP 43x14 (Folding propeller)  
 Length: 1082mm  
 Weight (including propeller adapter): 427g\*  
 Single blade: 146g\*  
 Blade Material: Carbon fibre-reinforced nylon composite material  
 \* Subject to the actual product.

## 07 Thrust Data Table

X9 Plus G2L-12S Thrust Load Curve

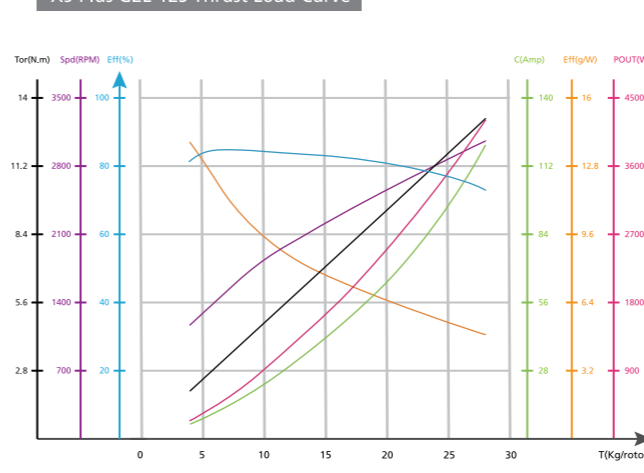

X9 Plus G2L-12S Lithium-ion Polymer Battery Thrust Data Table

Voltage(V)	Propeller	Throttle(%)	Thrust(kg)	Current(A)	Power Input(W)	Speed(RPM)	Efficiency(g/W)	Torque(N·m)	Power Output(W)	Temperature(°C)
48V (12S LiPo)	MFP 43x14	37%	4992	7.9	377.9	1278	13.2	2.36	315.8	
		39%	5971	10.1	484.1	1395	12.3	2.80	409.0	
		42%	7019	12.8	613.4	1513	11.4	3.29	519.6	
		45%	7936	16.4	737.9	1610	10.8	3.71	625.5	
		48%	9079	18.8	905.0	1723	10.0	4.24	765.0	
		51%	11077	25.5	1226.5	1902	9.0	5.17	1029.7	
		54%	11906	28.5	1368.9	1971	8.7	5.56	1147.5	
		57%	12967	32.5	1559.2	2055	8.3	6.05	1301.9	
		60%	14054	36.7	1762.6	2137	8.0	6.56	1467.9	
		63%	16074	45.1	2166.6	2280	7.4	7.49	1788.2	
		66%	16995	49.2	2363.1	2343	7.2	7.92	1943.1	
		69%	19107	59.3	2847.1	2484	6.7	8.89	2312.3	
		72%	20055	64.2	3062.2	2546	6.5	9.33	2467.3	
		75%	21002	69.4	3330.5	2608	6.3	9.78	2670.8	
		78%	23089	81.9	3928.9	2745	5.9	10.76	3092.8	
		81%	23977	87.7	4208.3	2802	5.7	11.18	3280.2	
		84%	25027	95.1	4561.9	2869	5.5	11.68	3506.9	
		87%	25985	102.3	4906.9	2929	5.3	12.13	3720.3	
		90%	26967	110.2	5283.8	2989	5.1	12.59	3940.5	
		93%	28008	119.1	5712.8	3048	4.9	13.08	4174.6	
100%	28145	120.4	5771.7	3056	4.9	13.14	4204.8			

X9 Plus G2L-14S Thrust Load Curve

X9 Plus G2L-14S Lithium-Ion Polymer Battery Thrust Data Table

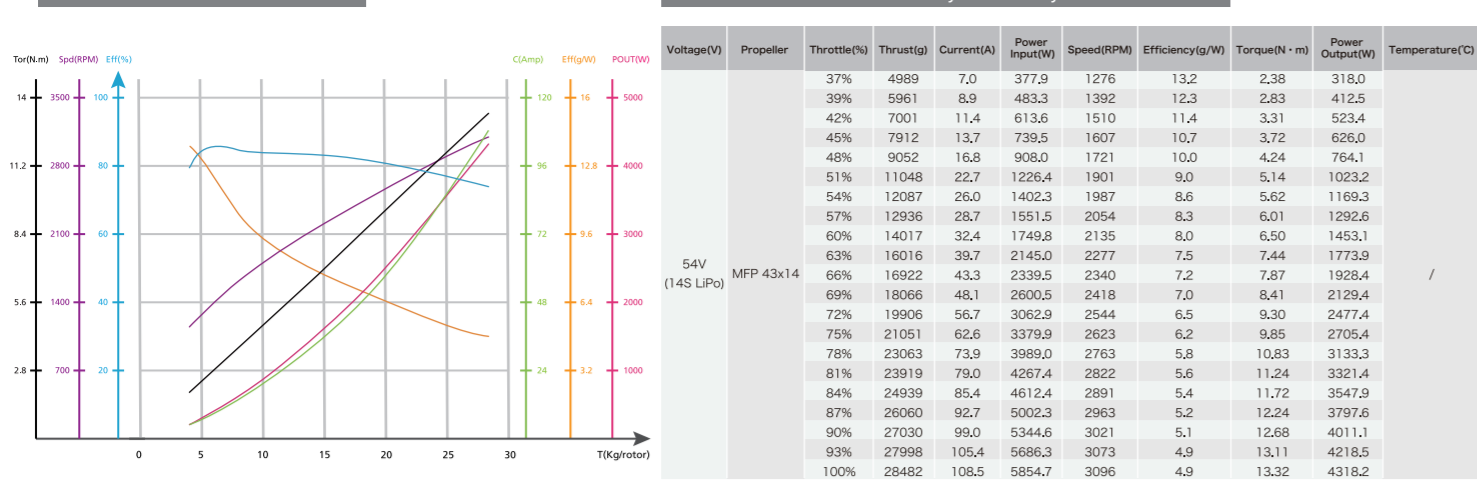

\* The above data was measured by HOBBYWING Laboratory at room temperature 25°C, at sea level, with varying throttle input adjustments.

## 08 Protection Functions

- Startup protection:** After the propulsion system is powered on, it enters self-check mode. If the check is successful, it will emit a string of beeping sound before operation. If the check fails, the motor cannot be driven with a flashlight warning.
- Stall protection:** When a motor stall is detected by the ESC, the motor will attempt to output for 1 second. If the stall continues during this time, the ESC will completely shut off output and will not attempt to restart the motor. At this point, re-power the propulsion system to clear the fault light and restore propulsion output.
- Overcurrent protection:** When the instantaneous current is abnormal and exceeds 280A for about 0.6ms, the ESC will turn off the output and continuously attempt to restart the motor. If multiple restart attempts fail, re-powering the propulsion system is required to restore normal operation.
- Throttle signal lost protection:** When the ESC detects a loss of throttle signal for more than 60ms, the throttle signal lost alarm will be triggered. After 1s loss, the output will shut down to prevent greater loss due to the propeller continuing to rotate at high speed. After the signal is restored, the ESC will restore power output accordingly.
- Startup delay protection:** The first time the motor starts, there will be a delay of approx. 400ms. During this period, the motor will rotate at low speed until the folded propellers are thrown off. Then, the motor will operate at full speed. During the startup period, the motor speed will not change, regardless of how much throttle is applied. When used with a flight controller, the automatic delay of the flight controller needs to be adjusted. Otherwise, it may lead to issues such as catapult takeoff of the UAV. For example, for the open-source Ardupilot, modify the MOT\_SPOOL\_TIME and TKOFF\_SLEW\_TIME to 2s. For closed-source flight controllers, please contact the manufacturer.
- Overtemperature warning:** The motor ESC has no temperature protection. When the ESC temperature exceeds 110°C or the capacitor temperature exceeds 100°C, the ESC LED will blink (refer to LED Status Explanation), and the CAN data will report an overtemperature warning externally, but the motor will not stop or reduce output. When the motor and ESC continue to overheat, there is a risk of burning.
- Back EMP (Back Electromotive Force) protection:** During throttle reduction, the motor ESC will generate back electromotive force. The ESC will perform corresponding logic processing to prevent high-voltage back electromotive force from damaging internal components. The back EMP voltage threshold is limited to 63V.

## 09 Warning Sound Description

The abnormal warning sound after the motor is powered on is related to the throttle signal and voltage anomalies. Check the input voltage and throttle.

Fault	Warning Sound	Possible Cause	Solution
The motor fails to start after power-on.	Rapid and single sound "Beep beep beep..."	The throttle is not reset to zero.	Set the throttle to the minimum.
The motor fails to start after power-on.	"Beep, beep, beep..." (Each 1-second interval)	The receiver throttle channel has no throttle signal output.	Check if the transmitter and receiver are properly paired. Check if the throttle control channel wiring is normal.
The power voltage is below 18V.	"Beep beep", "beep beep" (Each 1-second interval)	The battery voltage is too low.	Replace with a compatible fully charged battery.
The power-on voltage is above 63V.	"Beep beep", "beep beep" (Each 1-second interval)	The battery voltage is too high.	Replace with a compatible fully charged battery.

## 10 LED Status Explanation

Flashing Mode	Light Meaning	Solution
Looping 1 short flash	Overvoltage	Replace the battery (with a voltage lower than 63V).
Looping 2 short flashes	Undervoltage	Replace the battery (with a voltage higher than 18V).
Looping 3 short flashes	Overcurrent	<ul style="list-style-type: none"> <li>Re-power the propulsion system and check for any foreign objects in the motor.</li> <li>Check if there is no folding force between the blades and the propeller adapter.</li> <li>Contact the after-sales service.</li> </ul>
Looping 1 long flash	Throttle lost	<ul style="list-style-type: none"> <li>Check if the signal cable is connected to the flight controller.</li> <li>Check if the transmitter and flight controller are powered on.</li> <li>Check the resistance of the black and white wires. Contact after-sales if short-circuited.</li> </ul>
Looping (1 long flash + 1 short flash)	The throttle is not reset to zero.	If this issue occurs during motor rotation, check the aircraft battery and circuit.
Looping (1 long flash + 2 short flashes)	MOSFET overtemperature (above 110°C)	Wait for the propulsion system to cool down before re-powering.
Looping (1 long flash + 3 short flashes)	Capacitor overtemperature (above 100°C)	Wait for the propulsion system to cool down before re-powering.
Looping (1 long flash + 4 short flashes)	Triggered stall protection	<ul style="list-style-type: none"> <li>The motor can be restarted after the throttle is reset to zero.</li> <li>Check the motor for foreign objects and clear them before restarting.</li> </ul>
Looping (2 long flashes)	High-side open circuit	<ul style="list-style-type: none"> <li>Check if the motor is in good condition.</li> <li>Contact the after-sales service.</li> </ul>
Looping (2 long flashes + 1 short flash)	High-side short circuit	<ul style="list-style-type: none"> <li>Check if the motor is in good condition.</li> <li>Contact the after-sales service.</li> </ul>
Looping (2 long flashes + 2 short flashes)	Motor phase loss / broken wire	<ul style="list-style-type: none"> <li>Check if the motor is in good condition.</li> <li>Contact the after-sales service.</li> </ul>
Looping (2 long flashes + 3 short flashes)	Phase A operational amplifier malfunction	<ul style="list-style-type: none"> <li>Re-power the propulsion system to restore it to normal conditions.</li> <li>Contact the after-sales service.</li> </ul>
Looping (2 long flashes + 4 short flashes)	Phase B operational amplifier malfunction	<ul style="list-style-type: none"> <li>Re-power the propulsion system to restore it to normal conditions.</li> <li>Contact the after-sales service.</li> </ul>
Looping (3 long flashes)	Phase C operational amplifier malfunction	<ul style="list-style-type: none"> <li>Re-power the propulsion system to restore it to normal conditions.</li> <li>Contact the after-sales service.</li> </ul>

## 11 Daily Usage

### 1 Parameter Adjustment Using the Transmitter

The rotation direction and LED color of the X9 Plus G2L can be changed by moving the throttle stick on the transmitter. The parameter setting steps are as follows: Using the throttle stick on transmitter to set parameters is divided into four steps:

- Enter the setting mode;
- Select the parameter setting item;
- Select the parameter value; and
- Exit the setting mode.

**1. Enter the Setting Mode:**

Turn on the transmitter and move the throttle stick to the top position. Connect the ESC to the battery and wait 2 seconds until the motor emits a "11113" beep. Then, wait for another 5 seconds, the motor will emit the "11113" beep again, indicating that it has entered the setting mode. Proceed to the second step, "Select the parameter setting item".

**2. Select the Parameter Setting Item:**

After entering the setting mode, the motor will produce three types of beeps, which will loop in the following order. After a beep is heard, move the throttle stick to the bottom position within 3 seconds to enter the corresponding parameter setting item until the "3331" beep is heard. Proceed to the fourth step "Exit the setting mode".

1	"Beep"	Rotation Direction	(1 short beep)
2	"Beep-beep"	LED color	(2 short beeps)
3	"Beep-beep-beep"	Save and exit (Proceed to the fourth step).	(3 short beeps)

**3. Select the Parameter Value:**

After entering the setting item, the motor will emit beeps in a loop. After a beep is heard, move the throttle stick to the top position to select the parameter value corresponding to that beep. A "11113" beep indicates the parameters are temporarily saved. At this point, return to the second step to select other parameter items or exit the setting mode.

Parameter Value (Beep Sounds)	1 "Beep"	2 "Beep-beep"	3 "Beep-beep-beep"	4 "Beep-beep-beep-beep"	5 "Beep-"
1	Rotation Direction	CCW	CW		
2	LED color	Red	* Green	White	Blue

The default direction is CW or CCW marked on the propulsion system.

**4. Exit the Setting Mode:**

In the second step, after the motor emits the three short "beep-beep-beep" (i.e., the third setting item), move the throttle stick to the bottom position within 3 seconds to select "Save and Exit". Then, the motor will emit the "33112" beep, indicating all parameters are saved. To this end, the parameter adjustment process is finished and will proceed to the self-check step. Once the self-check is completed, the system is ready for use.

### 2 LED Color Adjustment

The LED is set to green in factory default. X9 Plus G2L has canceled physical LED switches, except using transmitter, the LED color can only be changed using the software or the flight controller via CAN. Tools such as DataLink V2, CAN analyzer, or flight controller can be used to change the LED color. The DataLink V2 needs to be purchased separately from Taobao, distributors, or HOBBYWING Sales; the CAN analyzer also needs to be purchased separately. For flight controller operation, contact the manufacturer to check if such changes are supported. Gray parameters are not available for adjusting during parameter setting. **Be cautious when changing advanced parameters, as the loop control parameters and motor control parameters involve the drive program control logic and affect actual flight performance. Ensure consistency in propulsion parameters of ESCs on the same aircraft. Incorrect parameters may cause your drones to crash.** This Manual only provides instructions for adjusting parameters of propulsion system via DataLink V2 and does not cover CAN analyzer or flight controller operations. For CAN analyzers, follow HWCAN/DroneCAN protocol (i.e., Cyphal (UAVCAN)). For flight controllers, contact the corresponding manufacturer.

#### DataLink V2 box Operation Method

- Wiring**  
Use the USB cable to connect the DataLink V2 box to the PC.  
ESC ----> DataLink V2 box connect as "Blank Red Gray" cable ----> "-" - CH1 CL1". No external power is required for the XT30 interface on the DataLink V2 box. The wiring diagram between the ESC and DataLink V2 box is shown below.
- Software Operation**

### 3 Replace the Propeller

- Use an Allen wrench to remove the two fastening screws of the blades, and replace them with new blades. If the propeller adapter also needs replacing, use tools to remove the fastening screws of the propeller adapter and replace the entire set of propeller adapter and blades.
  - When installing the propeller adapter and blades, first install the bottom cover of the propeller adapter on the motor, then install the blades, propeller washer, and top cover, and install the fastening screws. Note: after installing and fastening the propeller screws, there should be a certain folding force between the blades and the propeller adapter. Use medium-strength screw adhesive to ensure that the fastening screws of the propellers and the motor are tightened.
  - Make sure the unique codes of the two blade are consistent. If one blade is damaged, replace both.
- Note: If screws haven't been loosened for a long time, anaerobic thread adhesive on the screws may have solidified. Loosening screws with force may break them down or cause them to slip. Heat the screws with a hot air gun or hair dryer. Heat the screws to around 70°C and then use an Allen wrench to remove them.**

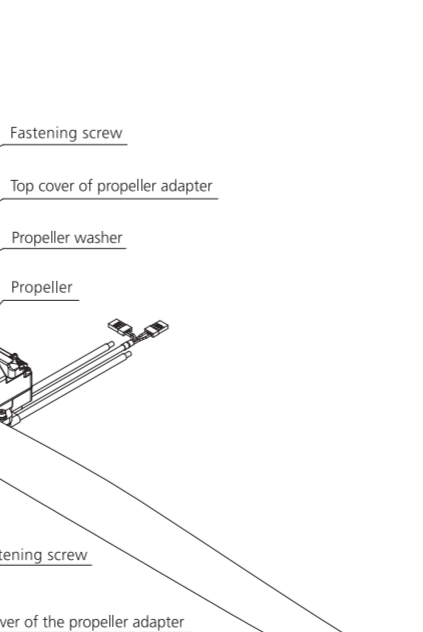

### 4 Firmware Upgrade

The software can be updated via online upgrade on PC or flight controller remote upgrade (OTA). Remote upgrade requires cooperation of the flight controller, this part is omitted. This function requires the DataLink V2, corresponding upgrade package (DataLink software with corresponding firmware), and a USB cable. The firmware version of DataLink V2 required is LINK-01.2.16-SC or later, for DataLink software, contact HOBBYWING for access. **Note: Ensure the computer has the Visual C++ Runtime Library installed before using this function. Otherwise, this function is not available. A typical upgrade package only contains one firmware for one type of ESC.** For other firmwares, obtain additional packages. For more details, refer to the DataLink V2 User Manual. Upgrade packages are available from the purchase locations, HOBBYWING's official website, distributors, and after-sales services. Since the driven algorithm of the ESC in propulsion system is FOC, the firmware is unique and can only be upgraded within certain versions. **Note: The upgrade can only be made from the existing firmware. Only the software can be upgraded, and the hardware can not.**

### CAN ESC Upgrade

- Wiring**  
Use the USB cable to connect the DataLink V2 box to the PC.  
ESC ----> DataLink V2 box connect as "Blank Red Gray" cable ----> "-" - CH1 CL1". No external power is required for the XT30 interface on the DataLink V2 box.
- Software Operation**  
Upgrade packages are available from the purchase locations, HOBBYWING's official website, distributors, and after-sales services. **Note: The upgrade can only be made from the existing firmware. Only the software can be upgraded, and the hardware can not.**

### 5 Using the CAN Parameter Adjustment Feature

Unless otherwise required, the ESC Node ID during ex-factory is 1, the throttle ID is 1, and the bus rate is 500kbps. The X9 Plus G2L unlocks multiple features for parameter adjustments. Parameters can be adjusted based on actual needs. In addition, throttle range adjustment, changing to DroneCAN protocol, and LED color change are supported. For detailed information, please refer to the relevant documents. To ensure proper usage, make sure that the firmware version of the DataLink V2 box is LINK-01.2.16-SC or later. **Be cautious when changing advanced parameters, as the loop control parameters and motor control parameters involve the drive program control logic and affect actual flight performance. Ensure consistency in propulsion parameters of ESCs on the same aircraft. Incorrect parameters may cause your drones to crash.** This feature can communicate with the flight controller and follow the HWCAN and DroneCAN protocols. For open-source flight controllers, follow the settings of both protocols. For commercial flight controllers, please contact the flight controller manufacturer. For Ardupilot flight controller, refer to <https://ardupilot.org/copter/docs/common-hobbywing-dronecan-esc.html>. For all other method of this feature except via flight controller, an additional purchase of the DataLink V2 box is required. Before using this feature, ensure that Microsoft Visual C++ 2013 is installed on the computer; otherwise, it will not work.

- Wiring**  
ESC ----> DataLink V2 box connect as "Blank Red Gray" cable ----> "-" - CH1 CL1". No external power is required for the XT30 interface on the DataLink V2 box. Connect the DataLink V2 box to the PC via USB cable. Power on the ESC. When changing the ID, please remove the propellers to avoid accidents. For one aircraft, Node IDs and Throttle IDs of different ESCs on one aircraft must not be the same. Otherwise, when using the CAN function, multiple ESCs with the same Node ID or Throttle ID will be recognized as one ESC.
- Operation**

### 6 Fault Storage

The Fault Storage function can record overvoltage, overcurrent, throttle lost, MOS overtemperature, capacitor overtemperature, motor stall, open-circuit faults, short-circuit faults, disconnection faults, etc. In case of any such faults, their accumulated fault count will increase by 1. This feature will also record the corresponding runtime and power-on count when the last fault occurred. The total power-on count is recorded. Each time the ESC is re-powered, the count value will increase by 1. The cumulative running time is recorded as well, which is the total time the ESC has been running. The manufacturers who produce complete drones can set the maintenance standards based on running times and power-on counts. This function requires a DataLink V2 box, DataLink software, serial port assistant, and a USB cable.

**Note: The DataLink software is available from HOBBYWING's official website, distributors, sales, and after-sales services.** Version requirement of DataLink V2 box: LINK-01.2.16-C or later; serial port assistant requirements: USB to TTL protocol; DataLink software should be the fault storage version, which can be obtained from the official website, WeChat official account, or after-sales service. The DataLink V2 box has three power supply methods (+5V), USB data cable, serial port assistant, or external power supply cable. Either one can be selected without the need for repeated power.

**Note: For details, please refer to the DataLink V2 box User Manual.**

- Wiring**  
Serial port assistant ----> DataLink V2 box "GND 5V TX RX" ----> "-" + RX2 TX2" (please follow the connection method);  
ESC ----> DataLink V2 box connect as "Blank Red Gray" cable ----> "-" - CH1 CL1". No external power is required for the XT30 interface on the DataLink V2 box. Multiple ESCs can be connected in parallel. **Note: When multiple ESCs are used in parallel, Node IDs and Throttle IDs of different ESCs used in parallel must not be the same. Otherwise, only one ESC can be recognized.**
- Software Operation**

### 7 Real-time Data Reading

Power on the propulsion system to transmit real-time data. The data format follows the HWCAN (default) and DroneCAN protocols. The real-time data can be viewed through the flight controller, DataLink V2 box, and CAN analyzer. For the flight controller and CAN analyzer, follow the HWCAN and DroneCAN protocols. The usage method is omitted in this Manual. This Manual only briefly introduces how to view the real-time data through DataLink V2 box. For Ardupilot flight controller, refer to <https://ardupilot.org/copter/docs/common-hobbywing-dronecan-esc.html>. For the closed-source flight controllers such as VK, Byaero and Jiyi, please contact the manufacturer of flight controller for usage instructions. The ESC will output real-time data for motor rotation speed, throttle, current, voltage, ESC temperature, MOSFET temperature, capacitor temperature, motor temperature, and ESC status. To measure the motor temperature, an additional temperature sensor must be installed in the motor, which is not provided with the standard motor. For the standard version, this value has no practical significance. For real-time data reading using DataLink V2 data box, a DataLink V2 box, DataLink software, serial port assistant, and a USB cable are required.

- Wiring**  
Serial port assistant ----> DataLink V2 box "GND 5V TX RX" ----> "-" + RX1 TX1" (please follow the connection method);  
ESC ----> DataLink V2 box connect as "Blank Red Gray" cable ----> "-" - CH1 CL1". No external power is required for the XT30 interface on the DataLink V2 box. Multiple ESCs can be connected in parallel. **Note: When multiple ESCs are used in parallel, Node IDs and Throttle IDs of different ESCs used in parallel must not be the same. Otherwise, only one ESC can be recognized, or no data will be recognized.**
- Operation**

### 8 Log Reading

By default, the propulsion system can store 1 hours of running logs. The data format follows the HWCAN (default) and DroneCAN protocols. The running logs can be viewed through the flight controller, DataLink V2 box, and CAN analyzer. For the flight controller and CAN analyzer, follow the HWCAN and DroneCAN protocols, the usage method is omitted in this Manual. This Manual only briefly introduces how to view the running log through DataLink V2 box. For the closed-source flight controllers such as VK, Byaero and Jiyi, please contact the manufacturer of flight controller for usage instructions. ESCs will record data for motor rotation speed, throttle, current, voltage, ESC temperature, MOSFET temperature, capacitor temperature, motor temperature, and ESC status. To measure the motor temperature, an additional temperature sensor must be installed in the motor, which is not provided with the standard motor. For the standard version, this value has no practical significance. For log reading using DataLink V2 data box, a DataLink V2 box, DataLink software, serial port assistant, and a USB cable are required.

- Wiring**  
Serial port assistant ----> DataLink V2 box "GND 5V TX RX" ----> "-" + RX1 TX1" (please follow the connection method);  
ESC ----> DataLink V2 box connect as "Blank Red Gray" cable ----> "-" - CH1 CL1". No external power is required for the XT30 interface on the DataLink V2 box. Multiple ESCs can be connected in parallel. **Note: When multiple ESCs are used in parallel, Node IDs and Throttle IDs of different ESCs used in parallel must not be the same. Otherwise, only one ESC can be recognized, or no data will be recognized.**
- Operation**

### 9 Other Functions

**CAN Function Expansion**  
The CAN function expansion needs to follow the HWCAN and DroneCAN protocols. After connecting to the flight controller, via CAN protocol, ESC status, digital throttle, ESC settings can be obtained, or ESC firmware be upgraded via flight controller, etc. For closed-source flight controllers, please contact the manufacturer of flight controller. For Ardupilot flight controller, refer to <https://ardupilot.org/copter/docs/common-hobbywing-dronecan-esc.html>. Pinout: The CAN cable is the two-colored cable (Red and Gray). Red indicates CAN-High, and gray indicates CAN-Low. To use CAN communication, the CAN protocol must be compiled with. Please contact HOBBYWING or the distributor to obtain the protocol. The bus rate can be set by yourself (default 500kbps). There is no CAN terminal resistor, which should be added to the flight controller during usage. Node ID and Throttle ID is default 1, which can be set by yourself during usage.

## 12 Maintenance

- When the drone is used for the first time or has not been used for a long time, remove the propellers, and check the motor rotation direction based on the flight controller's motor test function. Confirm the direction is right, and check whether the propellers and motors are installed correctly based on the motor rotation direction set in the flight controller. If any issues are found, modify them immediately.
- Unfold the propellers to a 180-degree horizontal position. While unfolding, check the tightness between the blades and the propeller adapters. If the blades are loose and there is no folding force between the blades and the propeller adapters, use an Allen wrench to tighten it again. Check the blades for cracks or chips. For blades made of plastic polymer, chips smaller than 2mm do not affect use. If chips larger than 2mm are detected, replace the propellers immediately.
- Before each flight, check whether the screws of the motor, propellers, and arms are tightly installed. During inspection, manually shake the relevant parts. If there is any loose part, tighten it immediately. Make sure to carefully check these parts as they are significant to the aircraft's flight safety. If any components show signs of aging or damage, replace them immediately.
- Conduct regular maintenance for the aircraft, such as after every 20 hours of flight or 200 flights, or after long-term storage of one month. During daily use and storage, the equipment may experience wear, aging, and failure.
- If the drone has not been used for a long time and there are dust and pesticide residue on the propellers and motors, remove them with a damp towel. Regular maintenance keeps the equipment in optimal condition for the next cycle of operations, reducing the risk of failure and improving operational efficiency.

## 13 After-sales Repair

In case of the propulsion system damage, please contact HOBBYWING's after-sales service promptly. As long as it does not affect performance, and after confirming with customer service staff, users may replace the damaged parts with HOBBYWING's original propulsion system components. However, users are prohibited from replacing non-original parts (such as screws, propeller adapters, blades, protective shields, etc.). If so, the manufacturer is not liable for any consequences caused therefrom.

#### Resources & Specifications

Visit [www.hobbywing.com/en/products/rotor-x9-plus-g2l](http://www.hobbywing.com/en/products/rotor-x9-plus-g2l) for more details about HOBBYWING X9 Plus G2L Drone Propulsion System