

# XRotor Pro

## X9 Plus

9620-100KV CW / CCW

### User Manual



Facebook



Instagram



LinkedIn



#### Disclaimer

Thank you for purchasing this HOBBYWING product! Brushless has big power. Any improper use may cause personal injury and damage to the device. We strongly recommend you read this user manual carefully before use and strictly abide by the stipulated operation procedures. We are not responsible for any using or alteration of the product, including but not limited to reimbursement for incidental or indirect loss.

#### Introduction

The X9 Plus brushless propulsion system is designed for applications in agriculture, education and training, logistics, fire fighting, surveying, inspection and other fields, with a single-axis rated load of 11-13kg and a maximum single-axis thrust of 27kg, integrated with 40mm carbon fiber tube arm. The waterproof grade is IPX7. It is resistant to rainwater, pesticides, salt spray, high temperature, sand and dust, impact, mud and soil. ESC FOC-motor PMS system has optimized computing, with multiple protection functions such as power-on self check, power-on voltage abnormal protection, over current protection, lock-up protection and etc. as well as real time data transmission.

#### Attentions

- When use it please keep away from crowd, high voltage cable and obstacles and conform to safety norm.
- Never approach to the high-speed rotating propeller & motor so as to avoid being injured by blade.
- Check if all the components are good before use. If there is any damaged component, please contact after-sale service for replacement.
- Check if the screw of connecting parts is loose or whether the motor is horizontal before flight.
- Power system can adjust LED color, acceleration rate, deceleration rate and brake force via software.
- You can use water to wash the motor after each operation to keep it clean.
- There is built-in brush centrifugal nozzle ESC(12V/1A) and can be connected and used directly.

#### Composition of the Power System

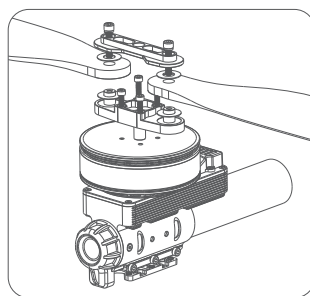

- Motor x 1
- ESC x 1
- Brush centrifugal nozzle ESC x 1
- Blade x 1
- Motor base x 1
- Fastening screw x several
- LED Set x 1

#### Installation of the Power System

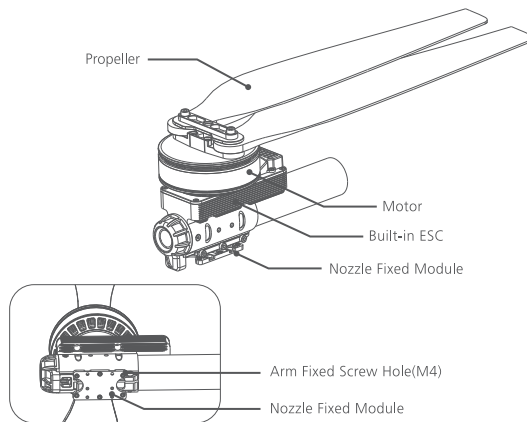

- The whole power system has been assembled before leaves the factory. Unpack and take out the power kit to install on the rack of plant-protection plane as per the rotation direction of motor.
- The hole diameter is 40mm so please use 40mm circular tube arm to install.
- The yellow/red/green color lines array plugs are data output and updating signal line(The yellow line is ground lead). The adjacent black and white lines plug is throttle signal line. The separated black and white plug line is throttle signal line of nozzle ESC.
- Data signal line real-time outputs input/output throttle, motor rotation speed, bus current, phase line current, bus voltage, capacitor temperature, temperature of MOS tube and other datas. ESC data communication bus divides CAN protocol and serial port communication protocol.
- The ESC throttle is solidified at 1100~1940μs.

#### General Specifications & Parameters

- Adapted uniaxial load: 11-13kg
- Maximum thrust: 27kg
- Adapted lithium cell: 14S(Maximum 60.9V)
- Use ambient temperature: -20°C---50°C
- Applicable carbon tube : 40mm
- Total weight: 1400g
- Protection grade: IPX7

#### Motor

- Stator size: 96\*20mm
- External diameter: 104mm
- KV value: 110KV

#### Blade: MFP 36x19

#### ESC

- Continuous current: 120A(Good heat dissipation)
- Support lithium cell: 12-14S
- Transient current: 150A(Good heat dissipation)
- Solidified throttle: 1100-1940us

#### Explanations for Protection

##### Start-up Protection:

When the motor is not started within 2 seconds after increase the throttle, ESC will close power output. Restart the motor only after the throttle trigger is at the bottom position. (Possible causes of this problem are: poor connection between ESC and motor or disconnection of individual output line; propellers are blocked by other objects.)

##### Motor Lock-up Protection:

The ESC will close output thoroughly and won't try to restart the motor when it detects the motor lock-up. At this time you need to place the throttle trigger to the bottom position first and then push it upward. Then clear the error and restart the ESC to resume the power output.

##### Current Protection:

The ESC will close output immediately when the transient current gets close to 300A. It will restore normal after you re-power on.

##### Throttle Signal Loss Protection:

The ESC will close output immediately when it detects throttle signal loss above 0.25 seconds. Prevent the propeller from rotating at high speed thus cause greater loss. After restoring signal, ESC will restore corresponding power output.

#### Daily Use

##### 1. Adjust parameters of ESC

Use DATALINK to connect parameter-adjusting software. It can adjust LED color (DIP switch can also adjust LED color.), rotation direction of motor, acceleration rate and deceleration rate of ESC and brake. The adjustment mode is interface type. Convenient and intuitive.

##### 2. Replace Propeller

- Use tool to remove the blade's fastening screw HM5x22 in order and then replace intact blade. If you need to change the blade clamp, also use tool to remove the blade clamp's fastening screw M4x16 and then replace the whole set of blade and blade clamp.
- Install the bottom cover onto the motor before installing blade clamp and blade. Then install the blades, propeller pad, top cover(blade clamp) in order and fasten them by screws. When install blade clamp and fastening screw, the screw glue must be used.

#### Maintenance & Repair

On the premise of not affecting performance, please contact Hobbywing's after-sales service in time if power system device is damaged. Make sure to contact after-sales service before replace the parts and outsourcing parts is not allowed (such as screw, blade clamp, blade). Contact after-sales to repair if serious damage occurs.

#### Troubleshooting & Alarming sounds

Trouble	Alarming sound	Possible Cause	Solution
The motor was unable to start after power on.	"BBB..." a single beep that repeats rapidly.	The throttle trigger was not moved to the bottom position.	Move the throttle trigger to the bottom position.
The motor was unable to start after power on.	"B, B, B..." a single beep that repeats (the time interval is 1 second).	No throttle signal output of receiver's throttle channel.	Check if the transmitter and receiver are well cooperated; check if the wiring of throttle control channel is normal.
The power-on voltage was below 18V.	"BB, BB, ..." a double beep that repeats (the time interval is 1 second.)	The battery voltage was too low.	Change a suitable full-charge battery.
The power-on voltage was above 64V.	"BBB, BBB, ..." a triple beep that repeats (the time interval is 1 second).	The battery voltage was too high.	Change a suitable full-charge battery.