



Thank you for purchasing this product! Please read the following statement carefully before use and, once used, it is considered to be an acceptance of all the contents. Please strictly observe and adhere to the manual installation with this product. Unauthorized modification may result in personal injury and product damage.



We reserve the rights to update the design and performance of the product without notice.

This propulsion system is an industrial-grade component for unmanned aircraft. If you have more specialized application requirements, please contact us.



Facebook

Instagram

LinkedIn

01 Introduction

The P115M is an industrial-grade brushless thrust system designed for multi-rotor aircraft, supporting a rated single-axis load of 115 kg with a maximum thrust of 240kg/axis, it supports carbon fiber tubes with a 80 mm diameter for installation. Featuring IPX5 protection and high-efficiency thermal dissipation, it delivers a one-step power solution for heavy-load multi-rotor drone applications across logistics, emergency rescue, construction lifting, and other critical domains. The FOC ESC employs CAN communication protocol and dual-redundant throttle control (digital/PWM), integrating power-on self-diagnostics, fault logging, over-current protection, and stall protection to ensure operational safety.

02 Precautions

- Please stay away from crowds, high-voltage lines, obstacles, etc. when using, and be sure to follow safety regulations when using.
- The thrust system contains FOC driven ESC, which needs to strictly match the motor parameters. The program is unique. It is only suitable for one combination of propellers and is not compatible with multiple combinations at the same time. If you need to change it, please contact the manufacturer. Unreasonable combinations will trigger ESC protection and make it unusable.
- The ESC is equipped with CAN/485 function. This manual only introduces the CAN communication version. When using the CAN function, the ESC ID and the throttle channel of the same aircraft can not be the same, otherwise the multiple ESCs will be recognized as one ESC.
- Do not install propellers for ground testing to avoid unnecessary danger.
- Be sure to connect all parts carefully. If the connection is poor, you may not be able to control the aircraft normally, or other unpredictable situations such as equipment damage may occur.
- If you need to weld the input and output wire connectors of the ESC, please ensure that the welding is reliable and use welding equipment with sufficient power.
- Do not use this thrust system when the external ambient temperature exceeds 55°C. The high temperature will destroy the ESC and may cause damage to the motor and cause your drone to crash.
- This product adopts a fully isolated design between protective earth (PE), power circuits, and low-voltage signal circuits, ensuring low-impedance connection (common grounding) between the motor base and ESC housing.
- When connecting the sensor-enabled cable, if sensor-assisted startup is used, calibration via the upper computer is required first. Without calibration, the motor will remain in sensorless startup mode. The motor temperature measurement (NTC) function works normally with or without calibration. The ESC program defaults to not requiring sensor-assisted startup; this logic is added solely to pursue stability during rapid motor startup and is not mandatory.
- The sensor cable and fixed-Props functionality cable share the same wiring. If either function is used, calibration is required for it to take effect.

03 Thrust system composition

- Motor x 2pcs
- ESC x 2pcs
- Propeller x 2pcs
- Motor mount x 1pcs
- Fastening screws
- Propeller spacer x 2pcs

Accessories package

- Yellow white cable adapter (150mm) x 1pcs
- Yellow red white cable adapter (150mm) x 1pcs
- LFB connector x 1pcs

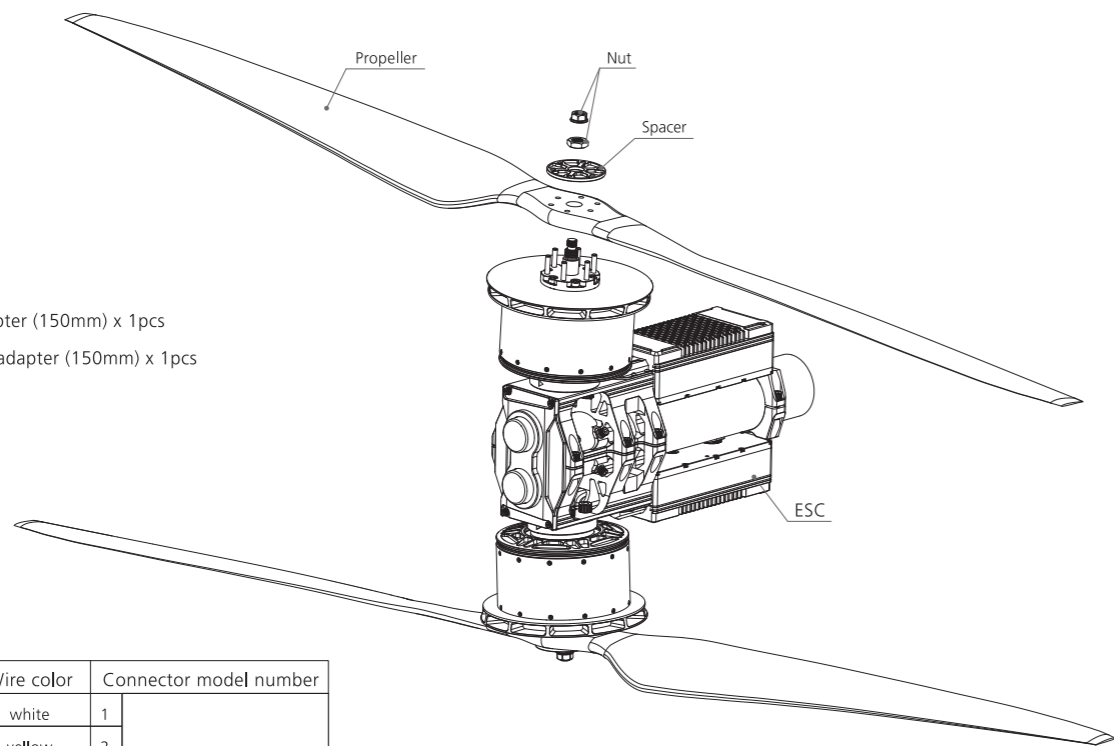

Sensor connector	Wire color	Connector model number
A	white	1
B	yellow	2
Z	green	3
PWM	purple	4
+5V	blue	5
PWM-GND	brown	6
Shielded	/	/
NTC	red	7
NTC-	black	8

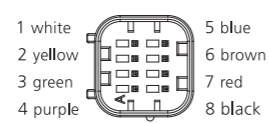

04 Thrust system installation

- The product comes standard with a signal cable adapter for debugging purposes. The P115M power units have two versions: the standard CAN communication version and the RS485 communication version (customizable). The pinout definitions are as follows:
Standard CAN communication version:
 The blue, red, and brown wires are the data output and firmware upgrade cable (for ESC firmware upgrades). The blue wire is CAN-GND, the red wire is CAN-High (abbreviated as CH), and the brown wire is CAN-Low (abbreviated as CL). The gray and green wires are the PWM throttle signal cable of the ESC. The gray wire is PWM-GND, and the green wire is the throttle signal line. The black wire is the shielded wire. The orange wire is the DC 24V power input wire, and the yellow wire is the DC 24V power GND wire.
RS485 communication version (customizable):
 If the RS485 bus version is chosen, the PWM throttle control function will be unavailable. The blue, white, and black wires are the RS485 communication cable: the blue wire is RS-GND, the white wire is RS485A, and the black wire is RS485B. The green and gray wires form the data output and firmware upgrade cable (for ESC firmware upgrades): the green wire is CAN-High (abbreviated as CH), and the gray wire is CAN-Low (abbreviated as CL). The black wire is the shielded wire. The orange wire is the DC 24V power input wire, and the yellow wire is the DC 24V power GND wire.
- The data signal cable outputs real-time data such as throttle, motor speed, bus current, bus voltage, capacitor temperature, SiC tube temperature, etc.
- The phase wire connection correspondence between the motor and ESC is: A-Blue, B-Yellow, C-Orange. When connected this way, the actual motor rotation direction is CW (Clockwise). To change the rotation direction, it should be configured via software.
- The standard sensor cable connector includes the motor temperature measurement (NTC) function via Pin7 and Pin8, which provide real-time feedback on motor temperature. The remaining pins are for the sensor cable, which also serve as the fixed-Props control cable.
- ESC PWM throttle range is fixed to 1100-1940µs, no need to do calibration.

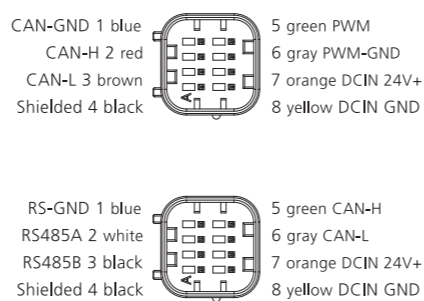

P115M Complete Propulsion System Accessory List

- 1-CW propulsion assembly x 1pcs
- 2-CCW propulsion assembly x 1pcs
- 3-Liner x 1pcs (With Ø80, 5mm-wall-thickness carbon tube)
- 4-ESC mounting tube dip holder x 1pcs
- 5-Cable protection silicone sleeve x 2pcs
- 6-Indicator light assembly x 1pcs
- 7-Propeller clamp assembly x 2pcs (Not standard (come with propeller))
- 8-M4 triple-combination screws x 4pcs (For locking indicator light)
- 9-M6 triple-combination screws x 12pcs (For locking CW/CCW propulsion assembly)
- 10-M6 screws x 12pcs (For locking propeller clamp)
- 11-M8 screws x 7pcs (For locking CW propulsion assembly)

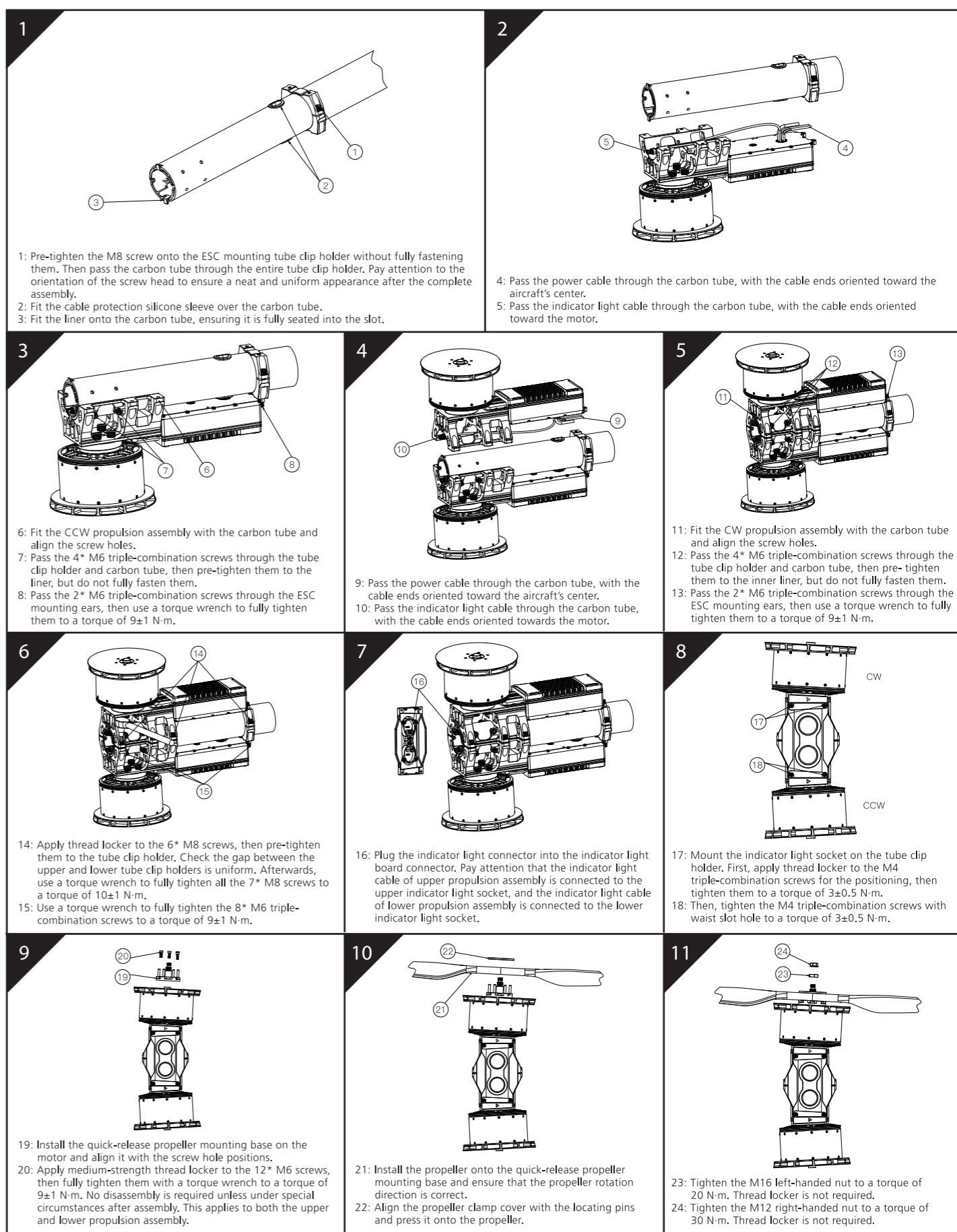
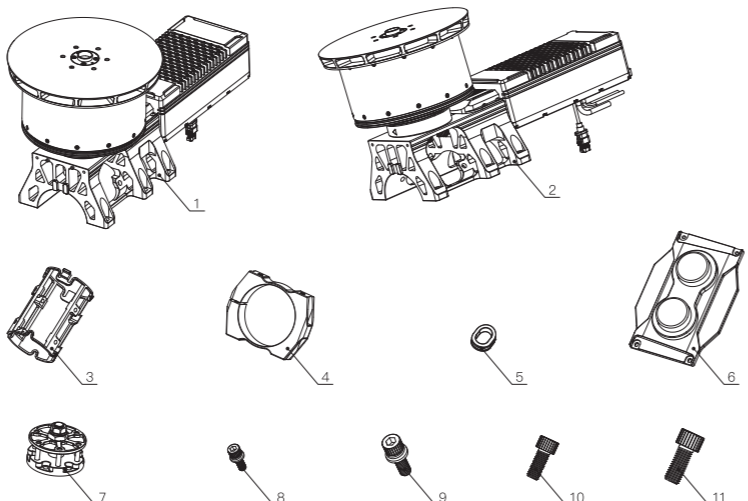

05 Specifications

Recommended uniaxial load: 115kg
 Max.Torque: 237kg (5KV)/232kg (5.5KV)
 Standard voltage range: 500V-850V
 Ambient temperature: -35~55°C
 Applicable carbon tube: 80mm (diameter)
 Total weight (Without propellers): 18.7kg±100g (5KV)
 17.5kg±100g (5.5KV)
 Protection level: IPX5
 Support throttle frequency: 50-500Hz
 Rated output power (Max continuous): 8453W(5KV single motor)/
 9121W(5.5KV single motor)

ESC
 Continuous current: 15A (Non-airtight ambient temperature <60 °C)
 Instantaneous current: 45A (3 seconds - good heat dissipation)
 Throttle solidified: 1100-1940µs
 Communication & digital throttle: CAN (Customizable RS485)
 Firmware upgrade: supported

Motor
 Stator size: 156*60mm/156*50mm
 Outer diameter: Ø167.1*0.1mm
 (with fun 209.9±1mm)
 KV rating: 5KV/5.5KV

Propeller
 Model: MSC 73x21-P / MSC 64x23-P
 Weight (straight propeller) : 1254g / 1035g

For 73-inch propellers:

The minimum operating voltage of the propulsion system is 500V when continuously outputting the rated thrust, and the maximum voltage is 850V. The minimum operating voltage of the propulsion system is 550V when outputting the maximum thrust for a short time, and the maximum voltage is 850V.

For 64-inch propellers:

The minimum operating voltage of the propulsion system is 500V when continuously outputting the rated thrust, and the maximum voltage is 850V. The minimum operating voltage of the propulsion system is 610V when outputting the maximum thrust for a short time, and the maximum voltage is 850V.

06 Thrust system parameters

MSC 73x21-P Load performance parameters (720V)

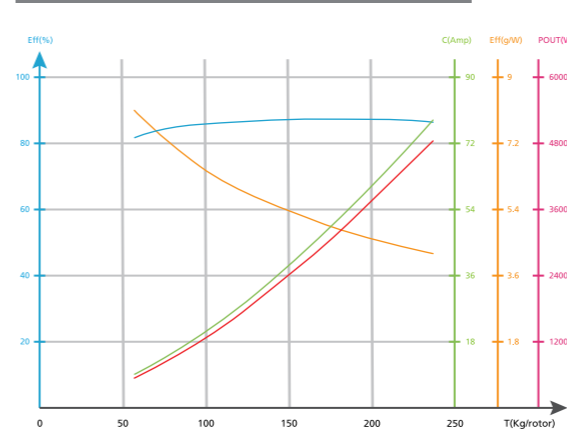

Voltage(V)	Propeller	Throttle(%)	Thrust(g)	Current(A)	Power Input(W)	Efficiency(%)	Efficiency(g/W)	Power Output(W)	Temperature(°C)
720V	MSC 73x21-P	38%	78640	15.2	10918.4	84.25	7.2	9198.8	
		40%	84432	16.8	12093.8	84.64	7.0	10295.2	
		42%	89950	18.4	13254.9	84.97	6.8	11502.7	
		44%	95367	20.1	14429.3	85.27	6.6	12933.9	
		46%	100619	21.7	15642.5	85.56	6.4	13583.7	
		48%	106409	23.5	16916.6	85.84	6.3	14521.2	
		50%	112207	25.4	18269.6	86.10	6.1	15730.2	
		52%	118258	27.4	19715.4	86.35	6.0	17024.2	
		54%	124500	29.6	21283.4	86.59	5.9	18409.8	
		56%	131169	31.9	22919.1	86.78	5.7	19899.2	
		58%	138000	34.3	24684.0	86.94	5.6	21460.3	
		60%	145033	36.9	26555.7	87.06	5.5	23119.4	
		62%	152214	39.6	28527.2	87.14	5.3	24858.6	
		64%	159477	42.5	30597.0	87.17	5.2	26692.7	
		66%	167447	45.5	32718.0	87.16	5.1	28517.0	
		68%	173946	48.5	34897.7	87.12	5.0	30428.9	
70%	180991	51.6	37098.0	87.06	4.9	32297.5			
72%	187801	54.6	39288.0	86.98	4.8	34171.0			
76%	200401	60.4	43480.2	86.81	4.6	37745.2			
80%	212397	65.6	47195.0	86.64	4.5	40889.8			
100%	237025	78.1	56198.4	86.07	4.2	48335.5			

MSC 73x21-P Load performance parameters (780V)

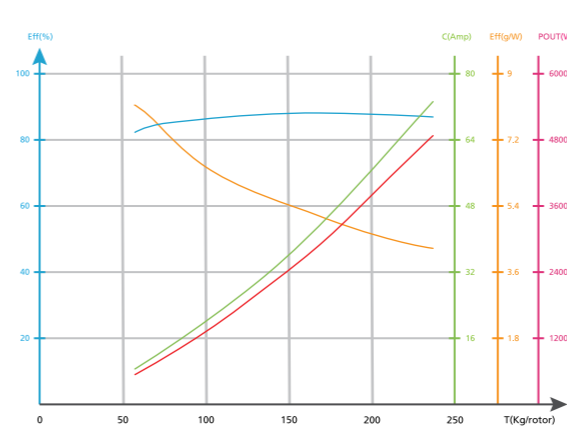

Voltage(V)	Propeller	Throttle(%)	Thrust(g)	Current(A)	Power Input(W)	Efficiency(%)	Efficiency(g/W)	Power Output(W)	Temperature(°C)
720V	MSC 73x21-P	38%	79910	14.1	10068.6	83.95	7.2	9206.1	
		40%	84645	15.6	11280.5	84.24	6.9	10260.8	
		42%	90137	17.2	13381.2	84.51	6.7	11308.5	
		44%	95558	18.7	14594.9	84.77	6.5	12372.1	
		46%	101043	20.3	15844.6	85.05	6.4	13475.8	
		48%	106580	22.0	17143.7	85.34	6.2	14635.3	
		50%	112569	23.8	18525.5	85.63	6.1	15853.4	
		52%	118717	25.6	19983.3	85.93	5.9	17171.7	
		54%	125150	27.6	21531.5	86.21	5.8	18562.3	
		56%	131857	29.7	23176.1	86.45	5.7	20035.8	
		58%	138810	32.0	24922.0	86.65	5.6	21594.9	
		60%	145984	34.3	26771.8	86.79	5.5	23235.3	
		62%	153258	36.8	28725.7	86.87	5.3	24954.0	
		64%	160623	39.5	30770.0	86.88	5.2	26740.8	
		66%	167980	42.2	32920.3	86.85	5.1	28591.3	
		68%	175247	45.1	35129.4	86.77	5.0	30481.8	
70%	182337	47.9	37376.5	86.68	4.9	32399.0			
72%	189167	50.8	39622.9	86.57	4.8	34330.5			
76%	201731	56.3	43930.8	86.36	4.6	37938.5			
80%	212397	61.2	47692.4	86.18	4.5	41101.3			
100%	237933	72.3	56345.0	85.64	4.2	48253.9			

MSC 64x23-P Load performance parameters (720V)

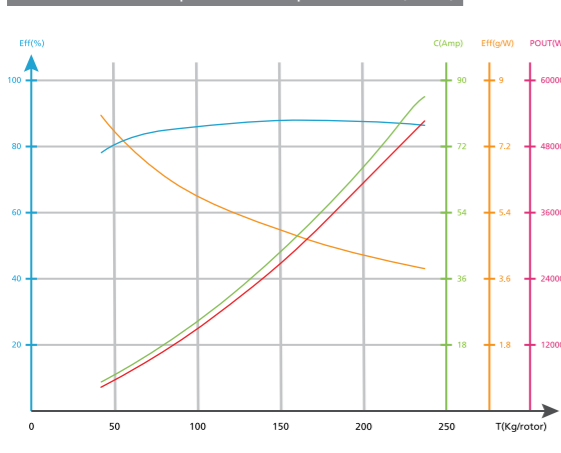

Voltage(V)	Propeller	Throttle(%)	Thrust(g)	Current(A)	Power Input(W)	Efficiency(%)	Efficiency(g/W)	Power Output(W)	Temperature(°C)
720V	MSC 64x23-P	38%	61545	12.2	8811.4	81.71	7.0	7199.8	
		40%	68571	14.2	10231.4	82.68	6.7	8459.3	
		42%	75796	16.3	11761.6	83.45	6.4	9815.0	
		44%	83145	18.6	13394.0	84.08	6.2	11261.3	
		46%	90908	21.0	15120.9	84.61	6.0	12793.8	
		48%	98138	23.5	16934.0	85.05	5.8	14402.3	
		50%	105702	26.1	18825.0	85.43	5.6	16082.2	
		52%	113268	28.9	20786.0	85.76	5.4	17826.0	
		54%	120810	31.7	22809.2	86.04	5.3	19625.1	
		56%	128352	34.6	24897.7	86.28	5.2	21473.1	
		58%	135720	37.5	27014.5	86.47	5.0	23359.4	
		60%	143042	40.5	29182.8	86.61	4.9	25275.2	
		62%	150248	43.6	31385.4	86.70	4.8	27211.2	
		64%	157316	46.7	33614.5	86.74	4.7	29157.2	
		66%	164229	49.9	35861.2	86.74	4.6	31106.0	
		68%	170965	52.9	38115.6	86.69	4.5	33042.4	
		70%	177506	56.1	40365.6	86.61	4.4	34961.5	
72%	183832	59.2	42602.2	86.50	4.3	36850.9			
76%	195750	65.2	46973.1	86.20	4.2	40490.8			
80%	206531	71.0	51106.0	85.89	4.0	43895.0			
85%	218072	77.3	55686.3	85.56	3.9	47645.2			
100%	232534	84.6	60885.1	85.17	3.8	51655.9			

MSC 64x23-P Load performance parameters (780V)

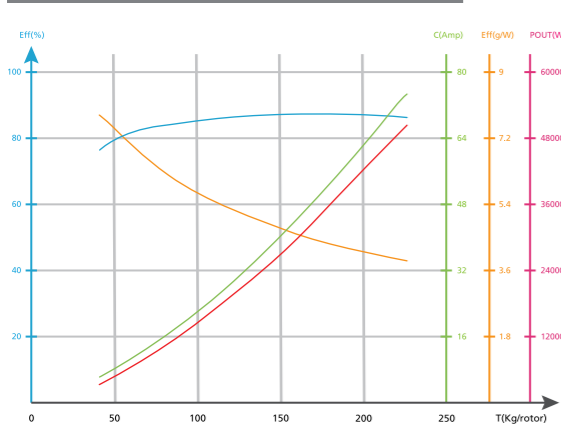

Voltage(V)	Propeller	Throttle(%)	Thrust(g)	Current(A)	Power Input(W)	Efficiency(%)	Efficiency(g/W)	Power Output(W)	Temperature(°C)
780V	MSC 64x23-P	38%	59358	10.9	8457.7	81.46	7.0	6914.1	
		40%	65978	12.6	9827.6	82.33	6.7	8091.1	
		42%	72724	14.4	11264.5	83.06	6.5	9356.3	
		44%	79600	16.4	12791.6	83.70	6.2	10706.6	
		46%	86598	18.5	14403.2	84.28	6.0	12129.1	
		48%	93707	20.6	16094.7	84.81	5.8	13649.9	
		50%	100908	22.9	17862.5	85.29	5.6	15234.9	
		52%	108179	25.3	19703.7	85.72	5.5	16890.0	
		54%	115491	27.7	21615.7	86.09	5.3	18608.9	
		56%	122815	30.3	23595.5	86.39	5.2	20384.2	
		58%	130115	32.9	25638.9	86.63	5.1	22211.0	
		60%	137358	35.6	27739.4	86.80	5.0	24077.8	
		62%	144506	38.3	29888.0	86.92	4.8	25978.7	
		64%	151522	41.1	32072.5	86.98	4.7	27896.7	
		66%	158370	43.9	34277.3	87.01	4.6	29824.7	
		68%	165015	46.8	36484.0	86.99	4.5	31737.5	
		70%	171424	49.6	38672.1	86.95	4.4	33625.4	
72%	177599	52.3	40819.4	86.90	4.4	35472.1			
76%	189551	57.6	44905.2	86.76	4.2	39590.9			
80%	199014	62.3	48592.9	86.61	4.1	42066.3			
85%	209661	67.3	52901.7	86.44	4.0	45382.5			
100%	225554	74.5	58146.4	86.21	3.9	50128.0			

*The above data is measured by HobbyWing laboratory at room temperature 25°C, sea level, change the throttle input adjustment, for reference only.

07 ESC protection function

This ESC is specially designed for industrial drones, without low-voltage protection and over-heat protection.

• Stall protection

When the ESC detects that the motor is locked, the ESC will completely turn off the output 1 second later and repeatedly try to restart the motor. Please land the aircraft as soon as possible if the motor is unable to be restarted. The power output can only be resumed after the power is turned off and restarted, and the fault is eliminated.

• Over current protection

When the instantaneous single-phase current abnormally reaches 120A, the ESC will turn off the output and keep trying to restart the motor. If the motor does not restart, it will return to normal after power on again.

• Over-heat warning

A fault message will be sent out through the data interface when the power components temperature is higher than 110°C or capacitor temperature is higher than 100°C. Please land the aircraft in time or reduce the throttle output when the ESC reports an over-heat fault, if the temperature continues to rise, electronic components may be damaged.

• Low voltage warning

When the voltage is below 490V, the ESC will fail the self-test, emit warning beeps, and report a Low-voltage fault. If the voltage is lower than 490V after passing the self-test, the ESC will only flash to warn that the voltage is too low. In this case, some components may work abnormally. Please land the aircraft immediately.

• Throttle signal lost protection

When the ESC detects that the throttle signal is lost, the output will be turned off immediately to avoid greater losses caused by the continued high-speed rotation of the propeller. After the signal is restored, the ESC will resume normal operation immediately.

08 ID setting

If there is no requirement, the default factory ID of the ESC is 1, the throttle channel is 1, and the bus speed is 500kbps.

This function requires the additional purchase of DataLink V2 box.

Before using this function, ensure that the computer system has installed Microsoft Visual C++ 2013 software in advance, otherwise it cannot operate normally.

1) Connection

ESC---->DataLink V2 box "blue red brown"---->" CH1 CL1"; Connect the data box to the computer via USB.

Connect the data box to the computer via USB.

When changing the ID, please remove the propeller to avoid danger. Please set ESC ID one by one.

For the same aircraft, different ESC IDs and throttles cannot be the same to avoid same ID recognizing as one ESC when using CAN function.

2) Operating diagram

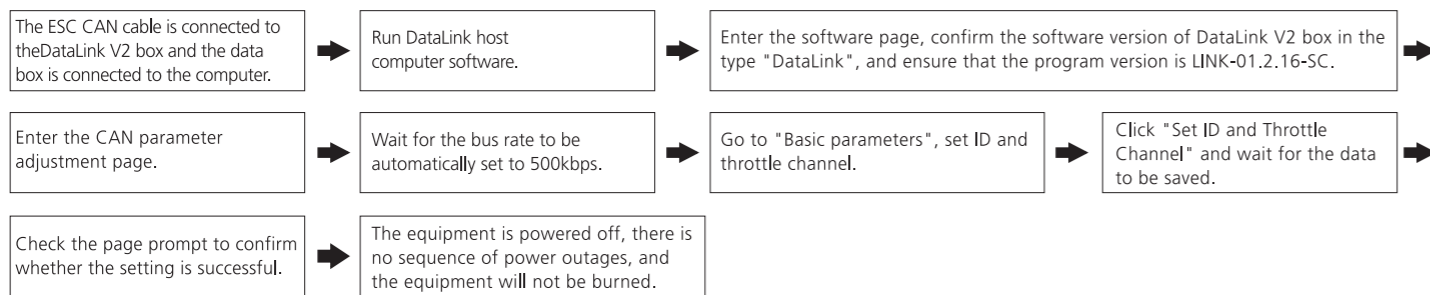

09 Fault data read

The ESC has its own fault storage function to store the power-on times, ESC running time, and fault times information, facilitates flight fault analysis. This function requires the additional purchase of DataLink V2 box and serial port assistant.

Note: DataLink software can be obtained from Hobbywing official website, dealers, Hobbywing sales, and Hobbywing after-sales.

DataLink V2 box firmware version requirements: LINK-01.2.16-C or later; serial port assistant requirements: USB to TTL protocol; DataLink software requirements: fault storage version. It can be obtained from the official website, WeChat official account or after-sales service.

The DataLink V2 box has three power supply methods (+5V), USB data cable, serial port assistant, and external power supply cable. You can choose one of the power supply methods, and you don't need to repeat the power supply.

Note: For detailed steps, please refer to the DataLink user manual.

1) Connection

Serial port assistant ----> DataLink V2 box "GND 5V TX RX" ----> "- + RX2 TX2" (please click here for the corresponding line sequence);

ESC---->DataLink V2 box "blue red brown" ---->" CH1 CL1", multiple ESCs can be used in parallel.

2) Software operation

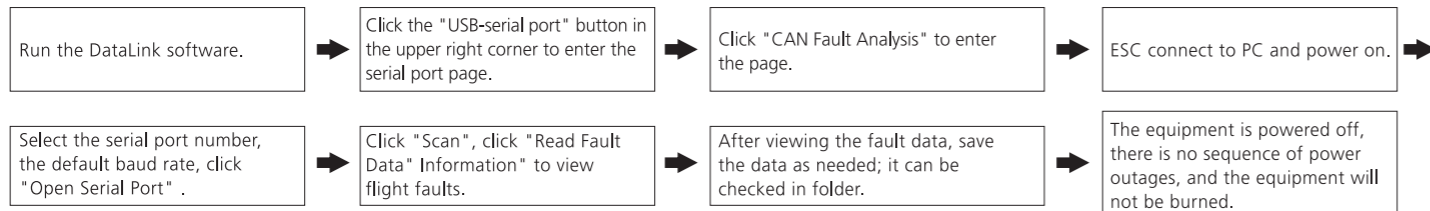

10 Firmware upgrade

Firmware upgrade is divided into two ways: computer online upgrade and flight controller remote upgrade. It supports online upgrade of multiple ESCs at the same time, and the upgrade port is CAN-ESC (Fast).

The upgrade of the flight control needs to cooperate with the flight control(not explained here).

This function needs to use DataLink V2 box, special DataLink software for upgrade package, and USB data cable.

DataLink V2 box version requirements, LINK-01.2.16-C or later; DataLink software can be obtained from Hobbywing official website, distributors, Hobbywing sales, and Hobbywing after-sales.

Note: Please ensure that the computer system has installed Microsoft Visual C++ 2013 software before using this function, otherwise it cannot be used. An upgrade package usually only contains one program for one type of ESC. For other ESCs, please re-obtain the upgrade package for the corresponding ESC model.

1) Connection

Connect the computer and the DataLink V2 box with the USB data cable;

ESC---->DataLink V2 box "blue red brown" ---->" CH1 CL1".

2) Firmware acquisition

It can be obtained at the place of purchase, Hobbywing official website, dealers, Hobbywing sales and Hobbywing after-sales offices.

Note: The upgrade can only be made from the existing firmware. Only the software can be upgraded, and the hardware can not.

3) Operating diagram

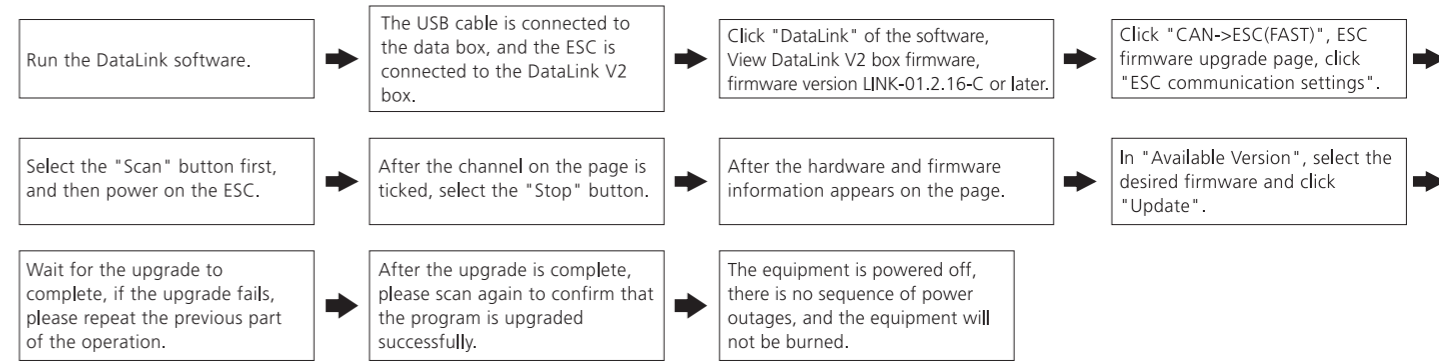

11 Common Faults and Prompt Sound Description

Warning tone description

Symptoms	Alarm tone	Possible causes	Solutions
Motor fails to start after power on	"Beep beep beep..." rapid monophonic	Throttle not reset to zero	Push the throttle to the lowest point or recalibrate the throttle point
Motor fails to start after power on	"Beep, beep, beep..." (1 second for each interval)	Receiver throttle channel has no throttle signal output	1. Check whether the transmitter and receiver operates normally 2. Check whether the throttle control channel wiring is normal
The power-on voltage is lower than 500V DC	"Beep, beep" (interval 1 second)	Battery voltage is too low	Replace with a suitable fully charged battery
The power-on voltage is higher than 850V DC	"Beep, beep" (interval 1 second)	Battery voltage too high	Replace with a suitable fully charged battery
The motor stops or restarts		The motor is not compatible with the ESC	Replace the motor, or replace the propeller
There is no sound during the self-test of the motor, but the motor can rotate	There is no prompt sound during self-test, and the motor rotates	Driver exception	1. Replace ESC 2. Return to factory for repair
The motor cannot start normally, accompanied by "click" "click" jitter	There is no prompt sound during the self-test, and the motor is unable to rotate	Motor phase loss	1. Check phase connection 2. Check motor 3. If there is no problem with the motor and connection, return the ESC to the factory for repair

12 The blinking of the light

Condition	normal	Full of throttle	Over voltage	Low voltage	Over current	Throttle loss	The input throttle signal is not at the 0% position	MOS overheat	Capacitor over heat	Motor block
Number of blinking of the light	The light is always on	Continuous short blinking	1 short	2 short	3 short	1 long	1 long and 1short	1 long and 2 short	1 long and 3 short	1 long and 4 short
Others										
Condition	The input throttle signal is not at the 0% position			Shorted circuit of signal line			Open circuit of motor			
Sound & blinking	Continous short loudly beep & LED continuous short blinking			Continuous short with blinking & LED off with LED off			Continous short blinking without beep			

13 Settings of LED color and CW/CCW

Please purchase the DataLink V2 box from Hobbywing or Hobbywing distributors. Please buy CAN analyzer if needed. Please contact the manufacture of your flight controller in advance to check if our products have communication protocol with your flight controller already. In parameter settings, gray area means unable to set. For other parameters, please do not modify at will to avoid crash.

We only include how to set parameters with DataLink V2 box in this user manual. If you are using CAN analyzer please follow HW CAN protocol document. If you are using flight controller to set ESC parameters, please contact the flight controller manufacture for help.

1) Connections

Connect PC and DataLink V2 box;

ESC---->DataLink V2 box"blue red brown" ---->" CH1 CL1", there is no need to connect the "+" pin on the box.No need to connect the XT30 plug to the battery, the DataLink V2 box can be powered by the USB-C cable.

2) RGB LED color list

	R	G	B
Red	✓	✗	✗
Green	✗	✓	✗
Blue	✗	✗	✓
White	✓	✓	✓
Purple	✓	✗	✓

3) Operating diagram

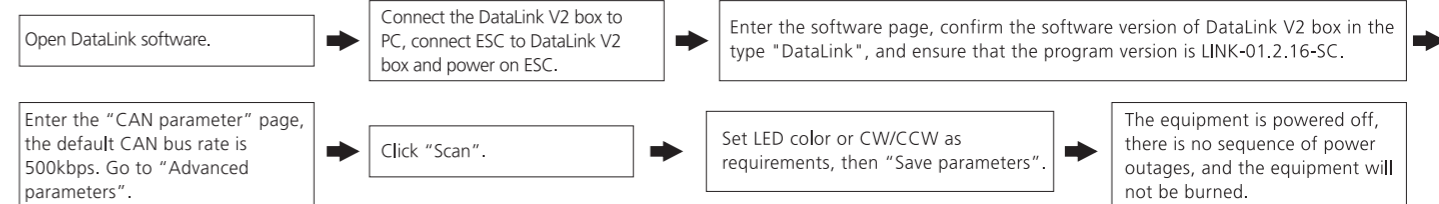

4) Datalink software

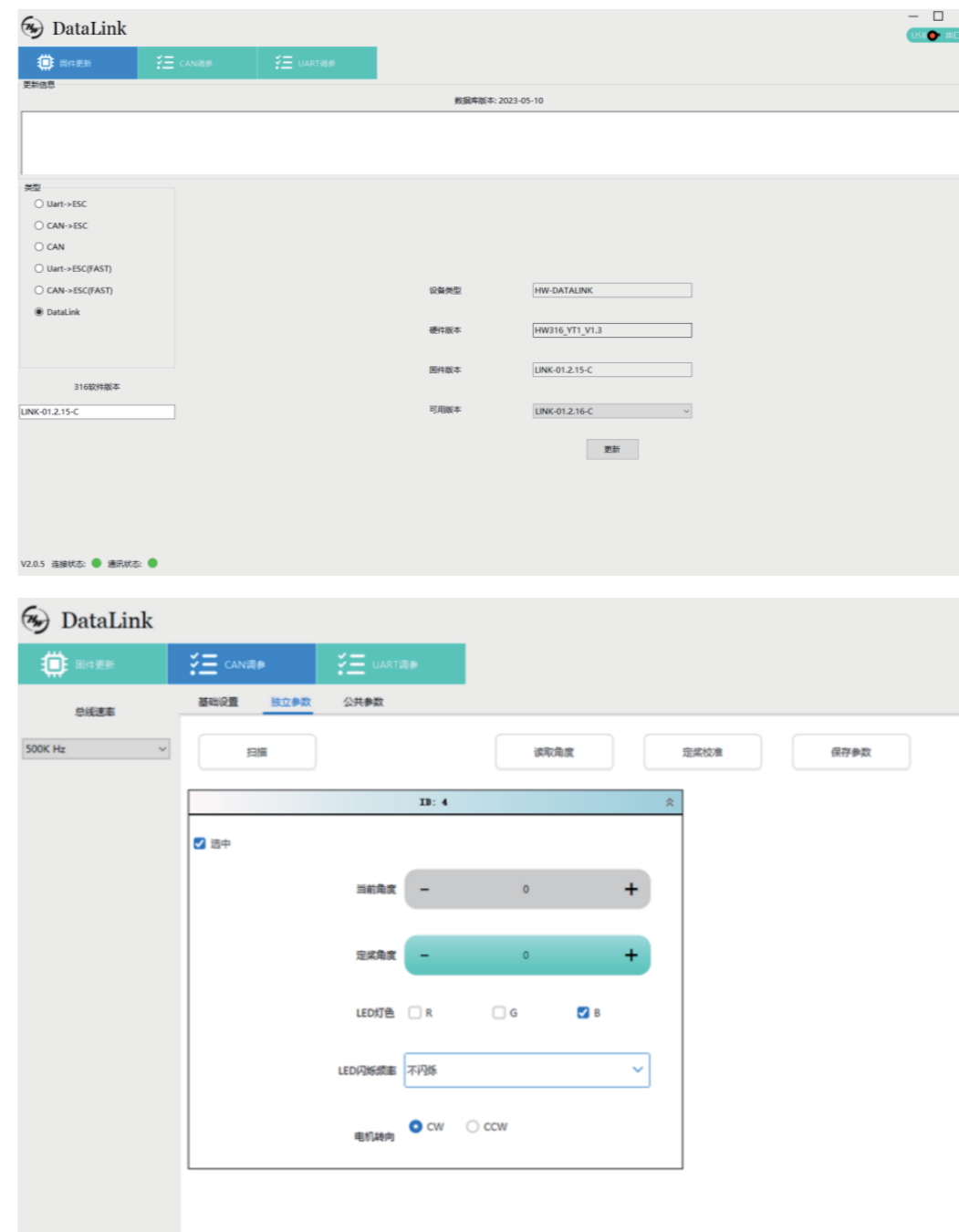

Resources & Specifications

Visit www.hobbywing.com/en/products/p115m for more details about P15M Integrated Drone Motor & ESC System