

## MFP 30x11S

### 技术参数 Specification

产品型号 Model	MFP 30x11S	单片重量 Single blade weight	54.5 g
主要材质 Material of blade	碳纤维增强尼龙复合材料 Carbon fiber reinforced nylon	单支重量 (含桨夹) Total weight (Including propeller adapter)	193 g
桨夹材质 Material of propeller adapter	铝合金 Aluminium alloy	使用环境温度 Operating temperature	-20~50 °C
存储温度 Storage temperature	-10~40 °C	存储湿度 Storage humidness	≤85 %
最佳转速范围 Recommended RPM range	2100~3500 RPM	常用拉力范围 Recommended thrust	4.0~12.0 kg
推荐最大转速 Max RPM	4050 RPM	极限拉力 Max thrust	17.0 kg
直桨/折叠桨 Non-folding/Folding	折叠桨 Folding propeller	推荐搭配动力 Recommended motors of HOBBYWING	X8 G2

### 尺寸图 Dimension Figure

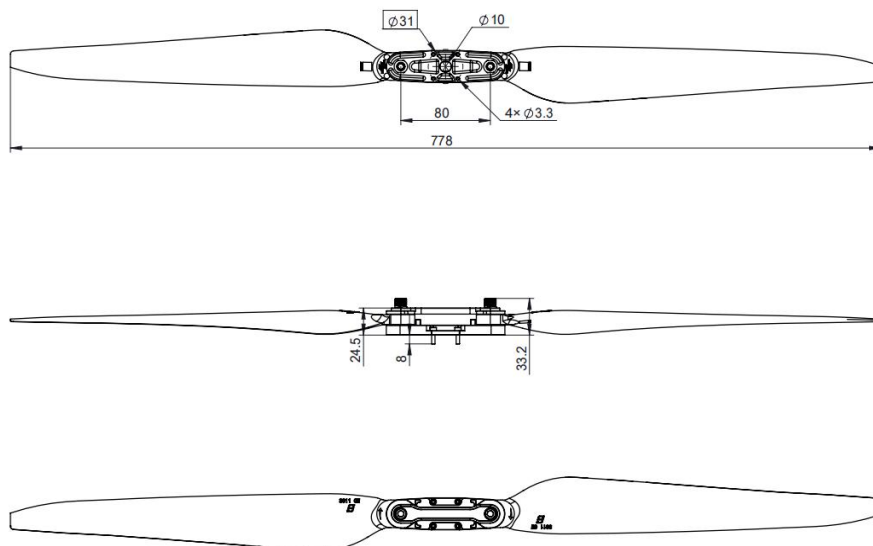

### 转速、拉力、扭矩测试数据 (54V) Speed, thrust and torque test data (54V)

