

MFP 30x11

技术参数 Specification

| | | | |
|---------------------------------------|--|--|-------------|
| 产品型号 Model | MFP 30x11 | 单片重量 Single blade weight | 51.6 g |
| 主要材质 Material of blade | 碳纤维增强尼龙复合材料 Carbon fiber reinforced nylon | 单支重量 (含桨夹) Total weight (Including propeller adapter) | 188 g |
| 桨夹材质 Material of propeller adapter | 铝合金 Aluminium alloy | 使用环境温度 Operating temperature | -20~50 °C |
| 存储温度 Storage temperature | -10~40 °C | 存储湿度 Storage humidness | ≤85 % |
| 最佳转速范围 Recommended RPM range | 1600~3500 RPM | 常用拉力范围 Recommended thrust | 2.0~10.0 kg |
| 推荐最大转速 Max RPM | 4050 RPM | 极限拉力 Max thrust | 15.0 kg |
| 直桨/折叠桨 Non-folding/Folding | 折叠桨 Folding propeller | 推荐搭配动力 Recommended motors of HOBBYWING | X8 |

尺寸图 Dimension Figure

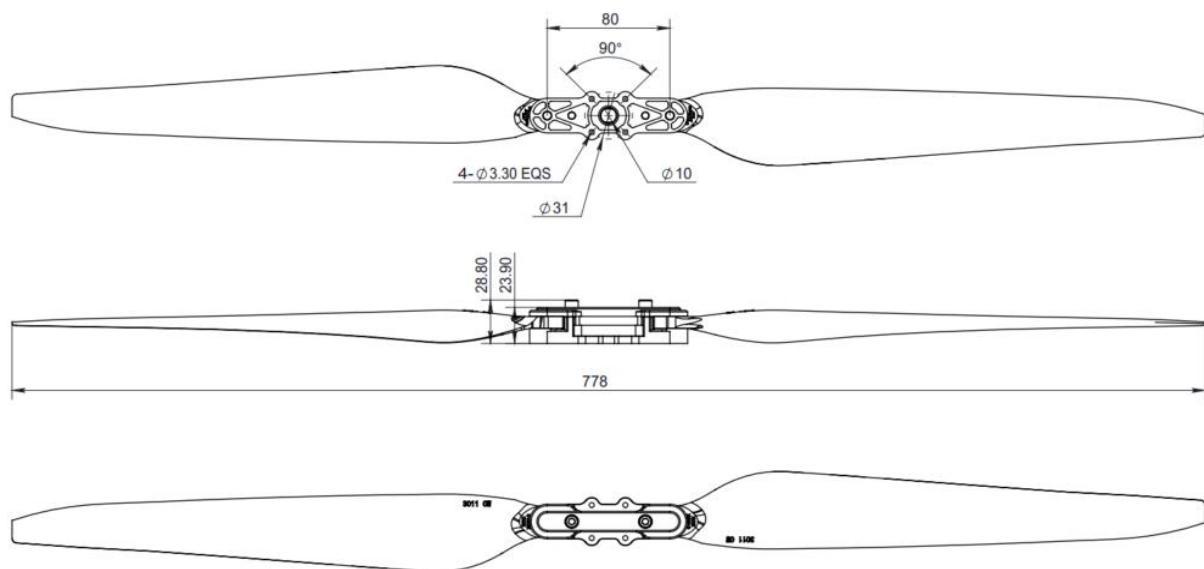

转速、拉力、扭矩测试数据 (46V) Speed, thrust and torque test data (46V)

